

SECTION **INT**  
INTERIOR

A  
B  
C  
D  
E  
F  
G  
H  
I  
INT  
K  
L  
M  
N  
O  
P

CONTENTS

<b>PRECAUTION</b> .....	3	<b>REAR SUNSHADE SWITCH</b> .....	17
<b>PRECAUTIONS</b> .....	3	Component Function Check .....	17
Precaution for Supplemental Restraint System (SRS) "AIR BAG" and "SEAT BELT PRE-TENSIONER" .....	3	Diagnosis Procedure .....	17
Precaution for Work .....	3	Component Inspection .....	18
<b>PREPARATION</b> .....	4	<b>SYMPTOM DIAGNOSIS</b> .....	19
<b>PREPARATION</b> .....	4	<b>REAR SUNSHADE DOES NOT OPERATE</b> .....	19
Special Service Tool .....	4	Diagnosis Procedure .....	19
Commercial Service Tools .....	4	<b>SQUEAK AND RATTLE TROUBLE DIAGNOSES</b> .....	20
<b>CLIP LIST</b> .....	5	Work Flow .....	20
Descriptions for Clips .....	5	Generic Squeak and Rattle Troubleshooting .....	21
<b>SYSTEM DESCRIPTION</b> .....	9	Diagnostic Worksheet .....	24
<b>COMPONENT PARTS</b> .....	9	<b>REMOVAL AND INSTALLATION</b> .....	26
Component Parts Location .....	9	<b>FRONT DOOR FINISHER</b> .....	26
Rear Sunshade Unit .....	9	Exploded View .....	26
Rear Sunshade Switch .....	9	Removal and Installation .....	27
<b>SYSTEM</b> .....	11	<b>REAR DOOR FINISHER</b> .....	29
System Description .....	11	Exploded View .....	29
<b>WIRING DIAGRAM</b> .....	12	Removal and Installation .....	29
<b>REAR SUNSHADE</b> .....	12	<b>BODY SIDE TRIM</b> .....	32
Wiring Diagram .....	12	Exploded View .....	32
<b>BASIC INSPECTION</b> .....	14	<b>DASH SIDE FINISHER</b> .....	32
<b>DIAGNOSIS AND REPAIR WORK FLOW</b> .....	14	DASH SIDE FINISHER : Removal and Installation .....	32
Work Flow .....	14	<b>FRONT PILLAR FINISHER</b> .....	33
<b>DTC/CIRCUIT DIAGNOSIS</b> .....	16	FRONT PILLAR FINISHER : Removal and Installation .....	33
<b>POWER SUPPLY AND GROUND CIRCUIT</b> .....	16	<b>FRONT KICKING PLATE</b> .....	34
<b>REAR SUNSHADE UNIT</b> .....	16	FRONT KICKING PLATE : Removal and Installation - Inner .....	34
REAR SUNSHADE UNIT : Diagnosis Procedure.....	16	FRONT KICKING PLATE : Removal and Installation - Outer .....	34

<b>REAR KICKING PLATE</b> .....	<b>34</b>	<b>FLOOR TRIM</b> .....	<b>44</b>
REAR KICKING PLATE : Removal and Installation - Inner .....	34	Exploded View .....	44
REAR KICKING PLATE : Removal and Installation - Outer .....	35	Removal and Installation .....	44
<b>BODY SIDE WELT</b> .....	<b>35</b>	<b>HEADLINING</b> .....	<b>47</b>
BODY SIDE WELT : Removal and Installation - Front .....	36	Exploded View .....	47
BODY SIDE WELT : Removal and Installation - Rear .....	36	Removal and Installation .....	48
<b>CENTER PILLAR LOWER FINISHER</b> .....	<b>36</b>	<b>TRUNK ROOM TRIM &amp; TRUNK LID FINISHER</b> .....	<b>51</b>
CENTER PILLAR LOWER FINISHER : Removal and Installation .....	36	Exploded View .....	51
<b>CENTER PILLAR UPPER FINISHER</b> .....	<b>36</b>	<b>TRUNK LID FINISHER</b> .....	<b>51</b>
CENTER PILLAR UPPER FINISHER : Removal and Installation .....	36	TRUNK LID FINISHER : Removal and Installation... ..	51
<b>REAR PILLAR FINISHER</b> .....	<b>37</b>	<b>TRUNK FLOOR CARPET</b> .....	<b>52</b>
REAR PILLAR FINISHER : Removal and Installation .....	37	TRUNK FLOOR CARPET : Removal and Installation .....	52
<b>REAR PARCEL SHELF FINISHER</b> .....	<b>39</b>	<b>TRUNK SIDE FINISHER</b> .....	<b>52</b>
Exploded View .....	39	TRUNK SIDE FINISHER : Removal and Installation .....	52
Removal and Installation .....	40	<b>TRUNK UPPER FINISHER</b> .....	<b>53</b>
<b>REAR SUNSHADE</b> .....	<b>41</b>	TRUNK UPPER FINISHER : Removal and Installation .....	53
Exploded View .....	41	<b>TRUNK REAR FINISHER</b> .....	<b>53</b>
Removal and Installation .....	41	TRUNK REAR FINISHER : Removal and Installation .....	54
<b>REAR SUNSHADE SWITCH</b> .....	<b>42</b>	<b>TRUNK HINGE FINISHER</b> .....	<b>54</b>
Exploded View .....	42	TRUNK HINGE FINISHER : Removal and Installation .....	54
Removal and Installation .....	42		

# PRECAUTIONS

< PRECAUTION >

## PRECAUTION

### PRECAUTIONS

#### Precaution for Supplemental Restraint System (SRS) "AIR BAG" and "SEAT BELT PRE-TENSIONER"

INFOID:000000012250305

The Supplemental Restraint System such as "AIR BAG" and "SEAT BELT PRE-TENSIONER", used along with a front seat belt, helps to reduce the risk or severity of injury to the driver and front passenger for certain types of collision. Information necessary to service the system safely is included in the SR and SB section of this Service Manual.

#### **WARNING:**

- To avoid rendering the SRS inoperative, which could increase the risk of personal injury or death in the event of a collision which would result in air bag inflation, all maintenance must be performed by an authorized NISSAN/INFINITI dealer.
- Improper maintenance, including incorrect removal and installation of the SRS, can lead to personal injury caused by unintentional activation of the system. For removal of Spiral Cable and Air Bag Module, see the SR section.
- Do not use electrical test equipment on any circuit related to the SRS unless instructed to in this Service Manual. SRS wiring harnesses can be identified by yellow and/or orange harnesses or harness connectors.

#### PRECAUTIONS WHEN USING POWER TOOLS (AIR OR ELECTRIC) AND HAMMERS

#### **WARNING:**

- When working near the Airbag Diagnosis Sensor Unit or other Airbag System sensors with the Ignition ON or engine running, DO NOT use air or electric power tools or strike near the sensor(s) with a hammer. Heavy vibration could activate the sensor(s) and deploy the air bag(s), possibly causing serious injury.
- When using air or electric power tools or hammers, always switch the Ignition OFF, disconnect the battery and wait at least three minutes before performing any service.

#### Precaution for Work

INFOID:000000011933615

- When removing or disassembling each component, be careful not to damage or deform it. If a component may be subject to interference, be sure to protect it with a shop cloth.
- When removing (disengaging) components with a screwdriver or similar tool, be sure to wrap the component with a shop cloth or vinyl tape to protect it.
- Protect the removed parts with a shop cloth and prevent them from being dropped.
- Replace a deformed or damaged clip.
- If a part is specified as a non-reusable part, always replace it with a new one.
- Be sure to tighten bolts and nuts securely to the specified torque.
- After installation is complete, be sure to check that each part works properly.
- Follow the steps below to clean components:
  - Water soluble dirt:
    - Dip a soft cloth into lukewarm water, wring the water out of the cloth and wipe the dirty area.
    - Then rub with a soft, dry cloth.
  - Oily dirt:
    - Dip a soft cloth into lukewarm water with mild detergent (concentration: within 2 to 3%) and wipe the dirty area.
    - Then dip a cloth into fresh water, wring the water out of the cloth and wipe the detergent off.
    - Then rub with a soft, dry cloth.
  - Do not use organic solvent such as thinner, benzene, alcohol or gasoline.
  - For genuine leather seats, use a genuine leather seat cleaner.

# PREPARATION

< PREPARATION >

## PREPARATION

### PREPARATION

#### Special Service Tool

INFOID:000000011933616

The actual shape of the tools may differ from those illustrated here.

Tool number (TechMate No.) Tool name	Description
— (J-39570) Chassis Ear	Locating the noise
— (J-50397) NISSAN Squeak and Rattle Kit	Repairing the cause of noise
— (J-46534) Trim Tool Set	Removing trim components

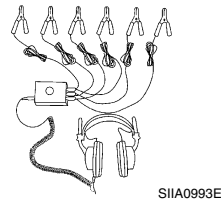

SIA0993E



ALJIA1232ZZ

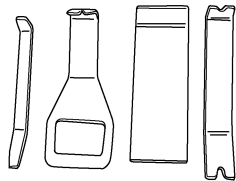

AWJIA0483ZZ

#### Commercial Service Tools

INFOID:000000011933617

(TechMate No.) Tool name	Description
(J-39565) Engine Ear	Locating the noise
( — ) Power Tools	Loosening nuts, screws and bolts

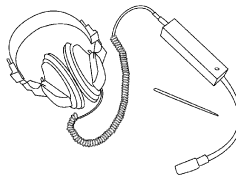

SIA0995E



PIIB1407E

# CLIP LIST







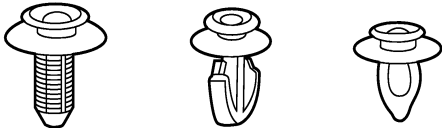

< PREPARATION >

## CLIP LIST

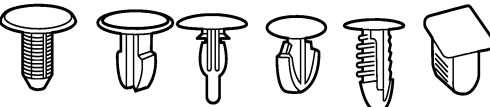
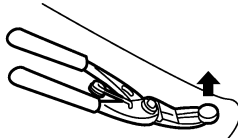
### Descriptions for Clips

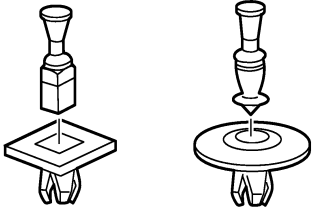
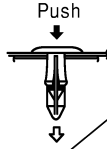
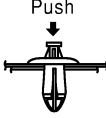
INFOID:000000011933618

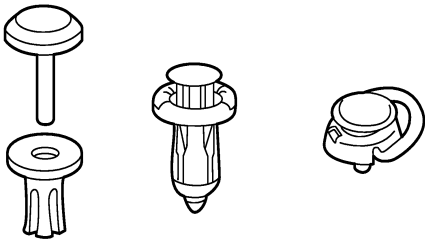
Replace any clips which are damaged during removal or installation.

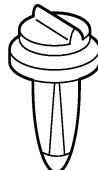
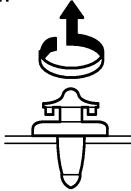





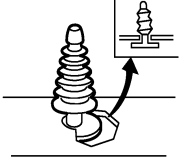
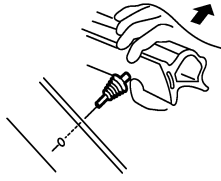

Symbol No.	Shapes	Removal & Installation
C101 		<p><b>Removal:</b> Remove by bending up with flat-bladed screwdrivers or clip remover.</p> 
C103 		 <p><b>Removal:</b> Remove with a clip remover.</p>
C203 		<p><b>Removal:</b> Push center pin to catching position. (Do not remove center pin by hitting it.)</p> <p>Push</p>  <p><b>Installation:</b></p> <p>Push</p> 
C205 		<p><b>Removal:</b></p> <p>Flat-bladed screwdriver</p>  <p>Clip</p> <p>Finisher</p>
C206 		<p><b>Removal:</b></p> 

SIIA0315E

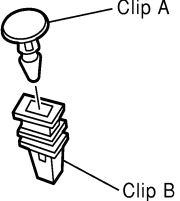
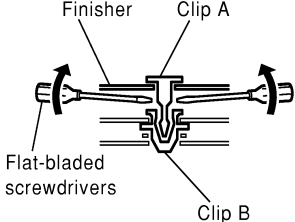
A  
B  
C  
D  
E  
F  
G  
H  
I  
INT  
K  
L  
M  
N  
O  
P

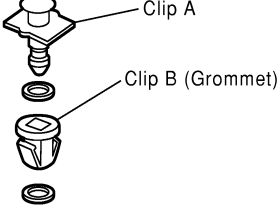
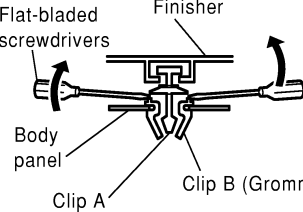
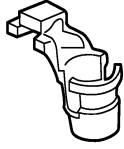
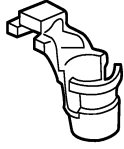
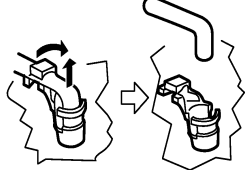
# CLIP LIST

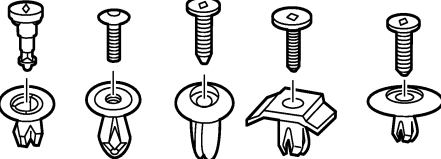







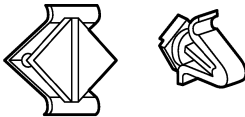

## < PREPARATION >

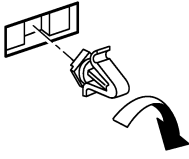
Symbol No.	Shapes	Removal & Installation
<p>CE103</p> 		<p><b>Removal:</b></p> 
<p>CF110</p> 		<p><b>Removal:</b></p> 
<p>CF118</p> 		<p><b>Removal:</b></p> 
<p>CR103</p> 		<p><b>Removal:</b> Holder portion of clip must be spread out to remove rod.</p> 
<p>CS101</p> 		<p><b>Removal:</b></p> <ol style="list-style-type: none"> <li>1. Screw out with a Phillips screwdriver.</li> <li>2. Remove female portion with flat-bladed screwdriver.</li> </ol> 

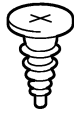
SIIA0316E

# CLIP LIST

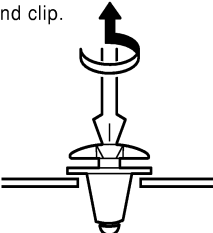
< PREPARATION >

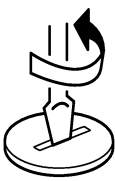



Symbol No.	Shapes	Removal & Installation	
CG101 		<b>Removal:</b>  Rotate 45° to remove	<b>Installation:</b> 
CS102 			
CS113 		<b>Removal:</b> Disconnect upper connection of clip with a flat-bladed screwdriver, then remove clip while inserting a flat-bladed screwdriver between body panel and clip. 	
C111 			

SIIA0317E

A  
B  
C  
D  
E  
F  
G  
H  
I  
INT  
K  
L  
M  
N  
O  
P

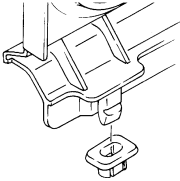
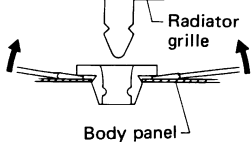
# CLIP LIST

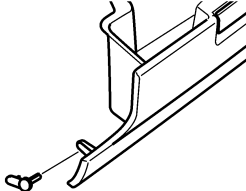
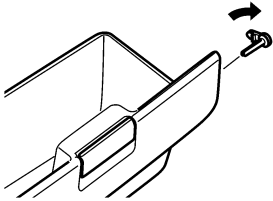
< PREPARATION >

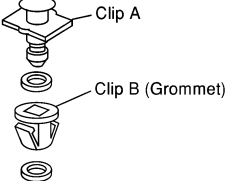
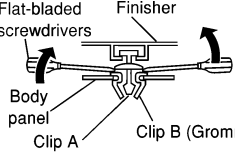
Symbol No.	Shapes	Removal & Installation
<p>CG104</p> 		<p><b>Removal:</b> Remove by bending up with flat-bladed screwdrivers.</p> 
<p>CE114</p> 		
<p>CF118</p> 		<p><b>Removal:</b> Flat-bladed screwdrivers Finisher screwdrivers</p> 

ALJIA0564GB



# COMPONENT PARTS

< SYSTEM DESCRIPTION >

## SYSTEM DESCRIPTION

### COMPONENT PARTS

#### Component Parts Location

INFOID:000000012156302

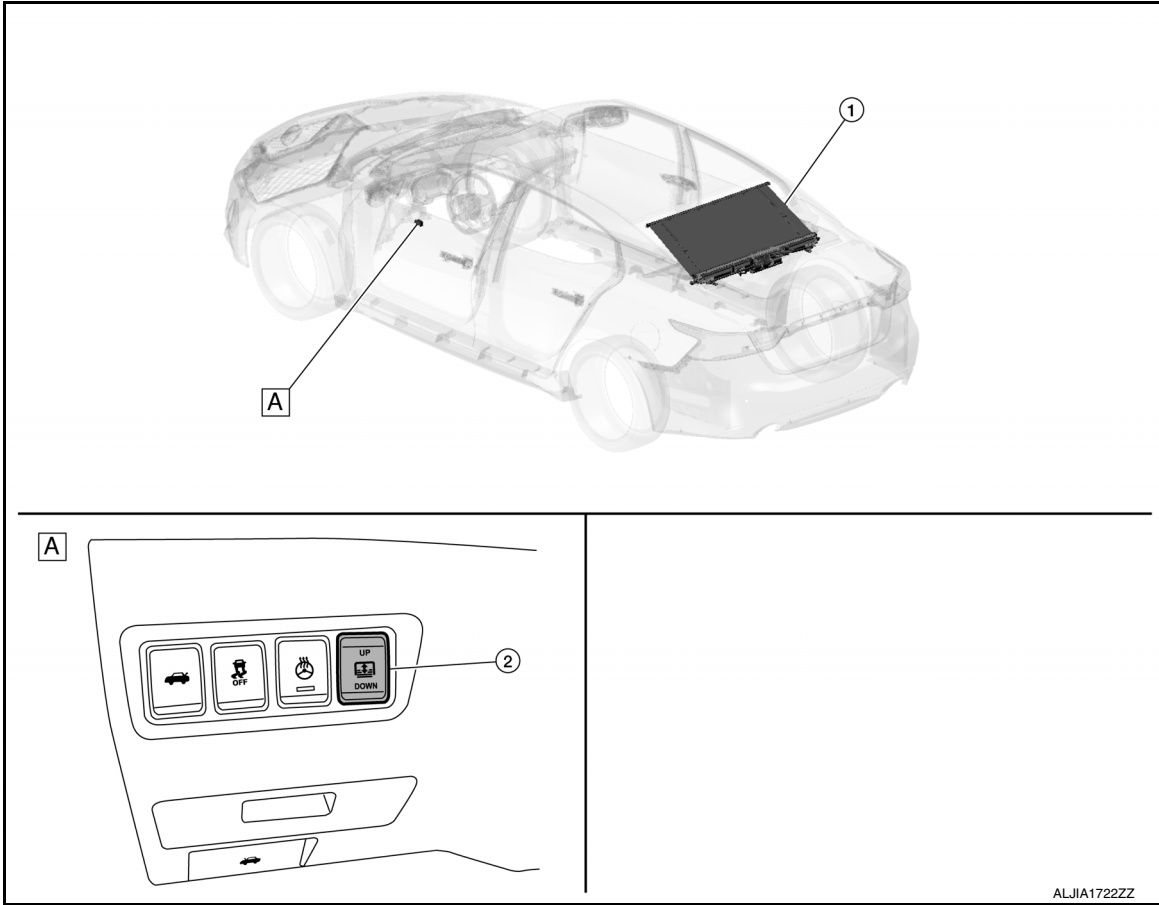

A. View of instrument lower panel LH

No.	Component	Function
1.	Rear sunshade unit	Refer to <a href="#">INT-9, "Rear Sunshade Unit"</a> .
2.	Rear sunshade switch	Refer to <a href="#">INT-9, "Rear Sunshade Switch"</a> .

#### Rear Sunshade Unit

INFOID:000000012193922

- Rear sunshade motor is installed on the rear sunshade unit.
- Rear sunshade motor receives up/down signal from the rear sunshade switch and operates the rear sunshade.

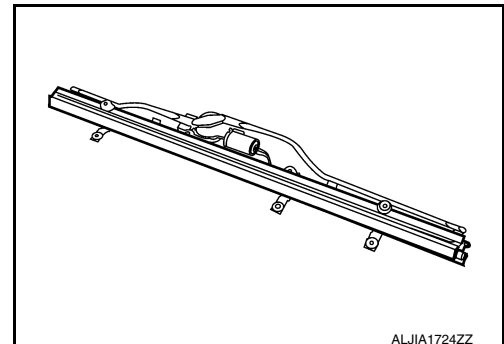

ALJIA1724ZZ

#### Rear Sunshade Switch

INFOID:000000012156303

## COMPONENT PARTS

### < SYSTEM DESCRIPTION >

Rear sunshade switch transmits up/down switch signal to the rear sunshade motor.

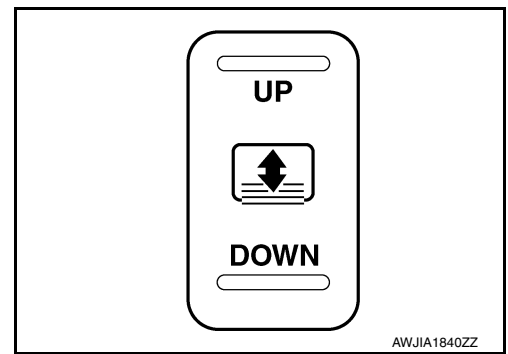

# SYSTEM

< SYSTEM DESCRIPTION >

## SYSTEM

### System Description

INFOID:000000012156305

### SYSTEM DIAGRAM

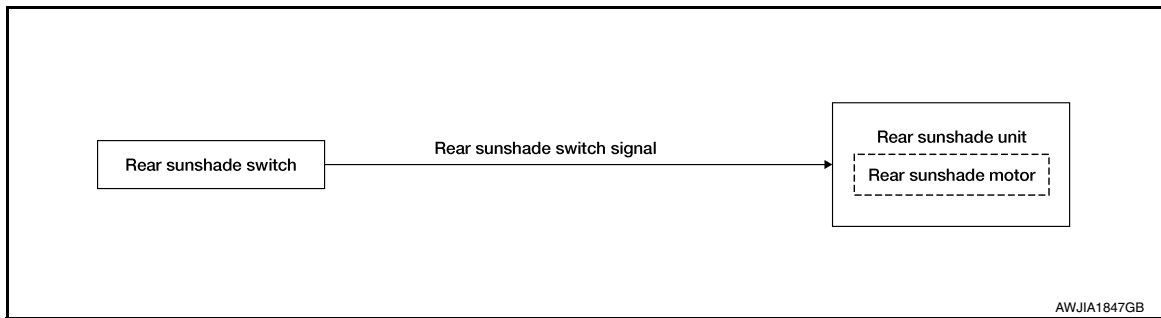

### REAR SUNSHADE OPERATION

- Rear sunshade switch signal is transmitted to rear sunshade unit when rear sunshade switch is operated.
- Rear sunshade unit operates rear sunshade motor and opens or closes rear sunshade.
- When rear sunshade reaches fully open or closed position or its operation is interrupted by an obstacle, rear sunshade unit detects overload of rear sunshade motor, interrupts power supply, and stops the operation.

A  
B  
C  
D  
E  
F  
G  
H  
I  
K  
L  
M  
N  
O  
P

INT

# REAR SUNSHADE

< WIRING DIAGRAM >

## WIRING DIAGRAM

### REAR SUNSHADE

Wiring Diagram

INFOID:000000011933610

REAR SUNSHADE

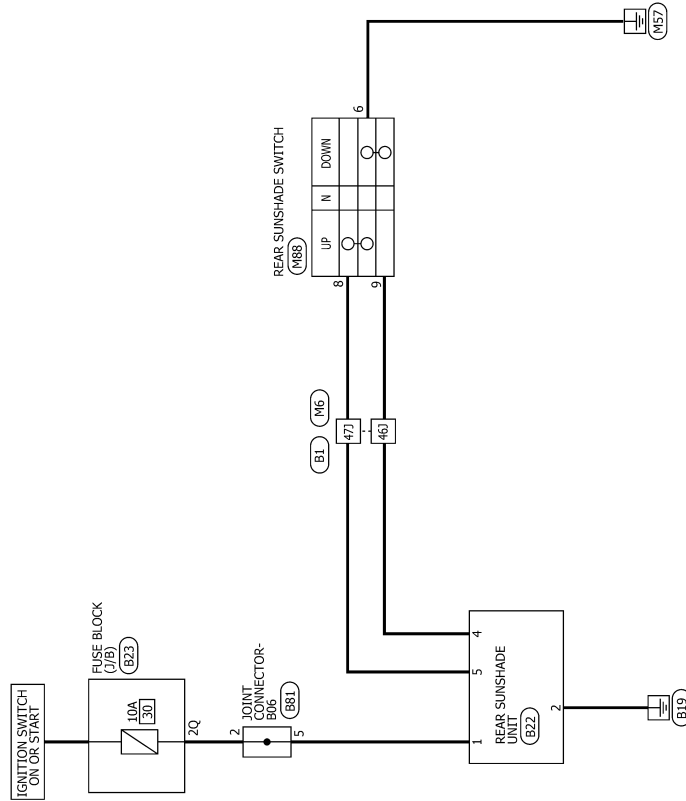

# REAR SUNSHADE

< WIRING DIAGRAM >

## REAR SUNSHADE CONNECTORS

Connector No.	M6
Connector Name	WIRES TO WIRES
Connector Type	TH80FDGY-CS16-TM4
Connector Color	GRAY

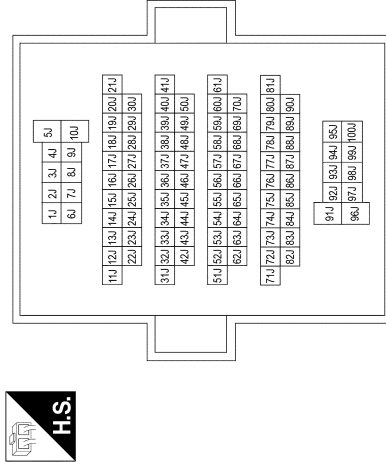

Terminal No.	Color of Wire	Signal Name
46J	R	-
47J	W	-

Connector No.	M88
Connector Name	REAR SUNSHADE SWITCH
Connector Type	TH10FB-NH
Connector Color	BLACK

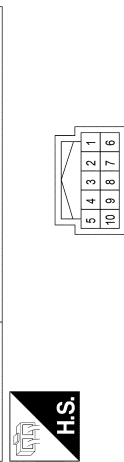

Terminal No.	Color of Wire	Signal Name
6	B	-
8	W	-
9	R	-

Connector No.	B1
Connector Name	WIRES TO WIRES
Connector Type	TH80MDGY-CS16-TM4
Connector Color	GRAY

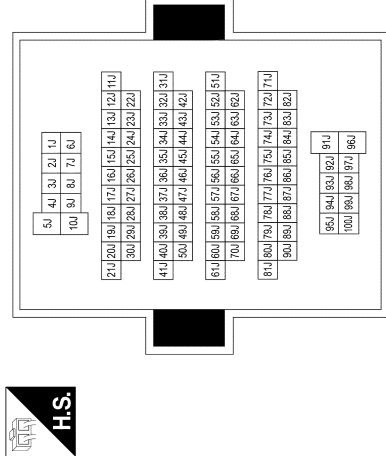

Terminal No.	Color of Wire	Signal Name
46J	P	-
47J	R	-

Connector No.	B22
Connector Name	REAR SUNSHADE UNIT
Connector Type	NS06MW-CS
Connector Color	WHITE

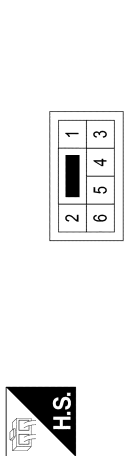

Terminal No.	Color of Wire	Signal Name
1	BG	-
2	B	-
4	P	-
5	R	-

Connector No.	B23
Connector Name	FUSE BLOCK (J/B)
Connector Type	NS08FW-CS
Connector Color	WHITE

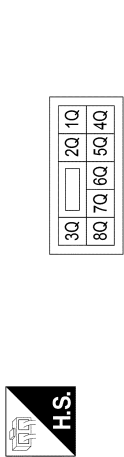

Terminal No.	Color of Wire	Signal Name
2Q	BG	-

Connector No.	B81
Connector Name	JOINT CONNECTOR-B06
Connector Type	A12FL
Connector Color	BLUE

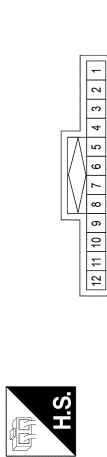

Terminal No.	Color of Wire	Signal Name
2	BG	-
5	BG	-

A  
B  
C  
D  
E  
F  
G  
H  
I  
INT  
K  
L  
M  
N  
O  
P

# DIAGNOSIS AND REPAIR WORK FLOW

< BASIC INSPECTION >

## BASIC INSPECTION

### DIAGNOSIS AND REPAIR WORK FLOW

Work Flow

INFOID:000000012156301

#### OVERALL SEQUENCE

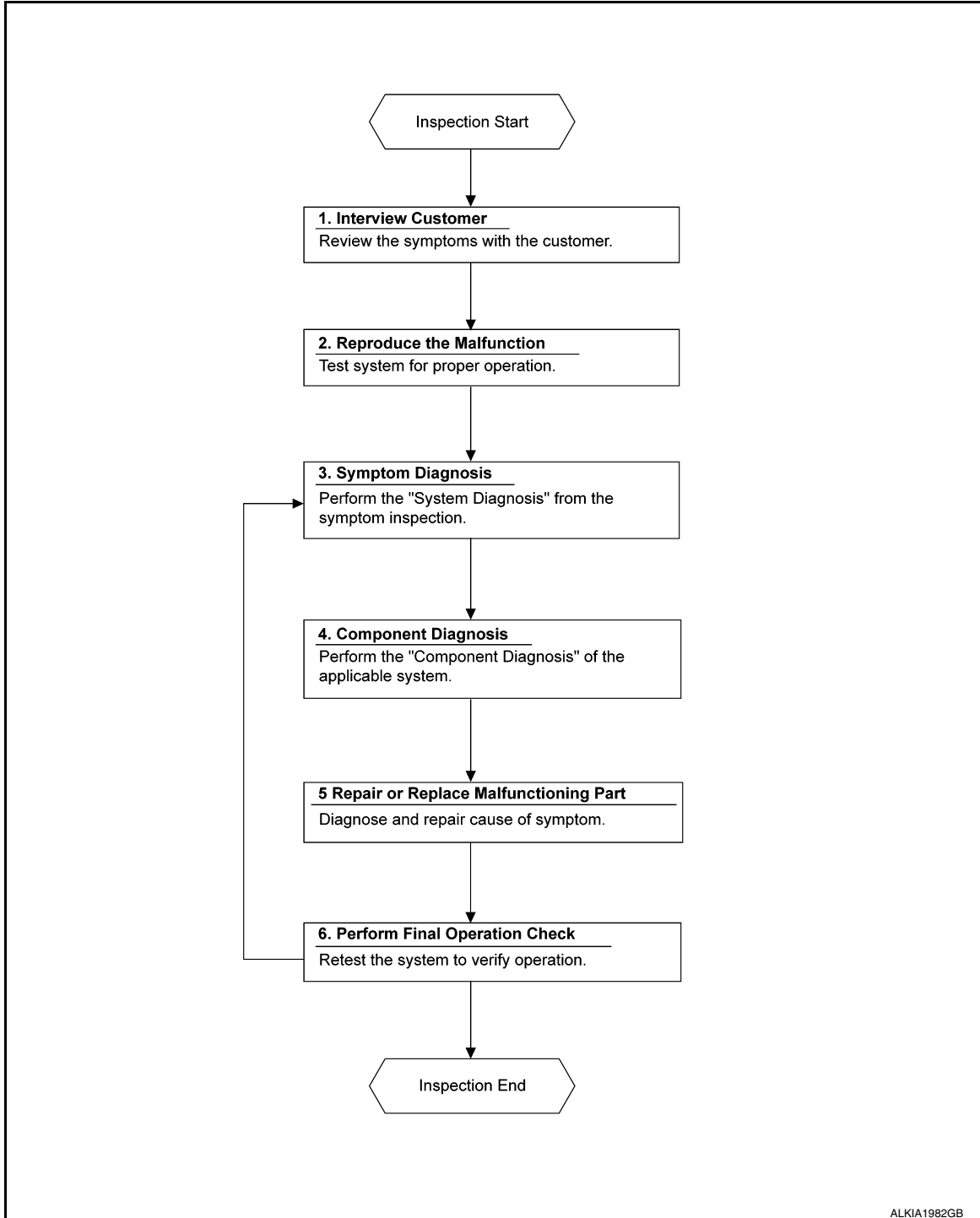

#### DETAILED FLOW

##### 1. INTERVIEW CUSTOMER

Interview the customer to obtain as much information as possible about the conditions and environment under which the malfunction occurred.

# DIAGNOSIS AND REPAIR WORK FLOW

< BASIC INSPECTION >

---

>> GO TO 2.

## 2. REPRODUCE THE MALFUNCTION

---

Reproduce the malfunction on the vehicle that the customer describes.  
Inspect the relation of the symptoms and the condition when the symptoms occur.

>> GO TO 3.

## 3. SYMPTOM DIAGNOSIS

---

Use Symptom diagnosis from the symptom inspection result in step 2 and then identify where to start performing the diagnosis based on possible causes and symptoms.

>> GO TO 4.

## 4. COMPONENT DIAGNOSIS

---

Perform the diagnosis with Component diagnosis of the applicable system.

>> GO TO 5.

## 5. REPAIR OR REPLACE THE MALFUNCTIONING PART

---

Repair or replace the specified malfunctioning parts.

>> GO TO 6.

## 6. PERFORM FINAL OPERATIONAL CHECK

---

Check that malfunctions are not reproduced when obtaining the malfunction information from the customer, referring to the symptom inspection result in step 2.

Are the malfunctions corrected?

YES >> Inspection End.

NO >> GO TO 3.

A  
B  
C  
D  
E  
F  
G  
H  
I  
K  
L  
M  
N  
O  
P

INT

# POWER SUPPLY AND GROUND CIRCUIT

< DTC/CIRCUIT DIAGNOSIS >

## DTC/CIRCUIT DIAGNOSIS

### POWER SUPPLY AND GROUND CIRCUIT

#### REAR SUNSHADE UNIT

#### REAR SUNSHADE UNIT : Diagnosis Procedure

INFOID:000000012156306

Regarding Wiring Diagram information, refer to [INT-12. "Wiring Diagram"](#).

### 1. CHECK FUSE

Check that the following fuse is not blown.

Signal name	Fuse No.
Ignition power supply	30 (10 A)

Is the fuse blown?

YES >> Replace the blown fuse after repairing the affected circuit.

NO >> GO TO 2.

### 2. CHECK REAR SUNSHADE UNIT POWER SUPPLY

1. Turn ignition switch OFF.
2. Disconnect rear sunshade unit connector.
3. Turn ignition switch ON.
4. Check voltage between rear sunshade unit harness connector and ground.

(+)		(-)	Condition		Voltage (Approx.)
Connector	Terminal				
B22	1	Ground	Ignition switch	ON	Battery voltage
				OFF	0 V

Is the inspection result normal?

YES >> GO TO 3.

NO >> Repair or replace harness or connector.

### 3. CHECK REAR SUNSHADE UNIT GROUND CIRCUIT

1. Turn ignition switch OFF.
2. Check continuity between rear sunshade unit harness connector and ground.

Rear sunshade unit		Ground	Continuity
Connector	Terminal		
B22	2		Yes

Is the inspection result normal?

YES >> Inspection End.

NO >> Repair or replace harness or connector.



# REAR SUNSHADE SWITCH

< DTC/CIRCUIT DIAGNOSIS >

## REAR SUNSHADE SWITCH

### Component Function Check

INFOID:000000012156307

#### 1.CHECK REAR SUNSHADE SWITCH FUNCTION

Operate rear sunshade switch and check rear sunshade operation.

Is the inspection result normal?

- YES >> Inspection End.
- NO >> Refer to [INT-17, "Diagnosis Procedure"](#).

#### Diagnosis Procedure

INFOID:000000012156308

Regarding Wiring Diagram information, refer to [INT-12, "Wiring Diagram"](#).

#### 1.CHECK REAR SUNSHADE SWITCH INPUT SIGNAL

1. Turn ignition switch ON.
2. Check voltage between rear sunshade switch harness connector and ground.

(+)		(-)	Condition	Voltage (Approx.)
Connector	Terminal			
M88	8	Ground	Rear sunshade switch is operated UP.	0 V
			Other than above	Battery voltage
	9		Rear sunshade switch is operated DOWN.	0 V
			Other than above	Battery voltage

Is the inspection result normal?

- YES >> GO TO 3.
- NO >> GO TO 2.

#### 2.CHECK REAR SUNSHADE SWITCH CIRCUIT

1. Turn ignition switch OFF.
2. Disconnect rear sunshade unit connector and rear sunshade switch connector.
3. Check continuity between rear sunshade unit harness connector and rear sunshade switch harness connector.

Rear sunshade unit		Rear sunshade switch		Continuity
Connector	Terminal	Connector	Terminal	
B22	4	M88	9	Yes
	5		8	

4. Check continuity between rear sunshade switch harness connector and ground.

Rear sunshade switch		Ground	Continuity
Connector	Terminal		
M88	8		No
	9		

Is the inspection result normal?

- YES >> GO TO 3.
- NO >> Repair or replace harness or connector.

#### 3.CHECK REAR SUNSHADE SWITCH GROUND CIRCUIT

## REAR SUNSHADE SWITCH

### < DTC/CIRCUIT DIAGNOSIS >

1. Turn ignition switch OFF.
2. Check continuity between rear sunshade switch harness connector and ground.

Rear sunshade switch		Ground	Continuity
Connector	Terminal		
M88	6		Yes

Is the inspection result normal?

- YES >> GO TO 4.  
 NO >> Repair or replace harness or connector.

### 4. CHECK REAR SUNSHADE SWITCH

Check rear sunshade switch.

Refer to [INT-18, "Component Inspection"](#).

Is the inspection result normal?

- YES >> Replace rear sunshade unit. Refer to [INT-41, "Removal and Installation"](#).  
 NO >> Replace rear sunshade switch. Refer to [INT-42, "Removal and Installation"](#).

### Component Inspection

INFOID:000000012156309

### 1. CHECK REAR SUNSHADE SWITCH

1. Turn ignition switch OFF.
2. Disconnect rear sunshade switch connector.
3. Check continuity between rear sunshade switch terminals under the following conditions:

Rear sunshade switch		Condition	Continuity
Terminals			
8	6	Rear sunshade switch is operated UP.	Yes
		Other than above	No
9		Rear sunshade switch is operated DOWN.	Yes
		Other than above	No

Is the inspection result normal?

- YES >> Inspection End.  
 NO >> Replace rear sunshade switch. Refer to [INT-42, "Removal and Installation"](#).

# REAR SUNSHADE DOES NOT OPERATE

< SYMPTOM DIAGNOSIS >

## SYMPTOM DIAGNOSIS

### REAR SUNSHADE DOES NOT OPERATE

#### Diagnosis Procedure

INFOID:000000012156310

#### 1. CHECK REAR SUNSHADE UNIT POWER SUPPLY AND GROUND CIRCUIT

Check rear sunshade unit power supply and ground circuit.

Refer to [INT-16, "REAR SUNSHADE UNIT : Diagnosis Procedure"](#).

Is the inspection result normal?

YES >> GO TO 2.

NO >> Repair or replace the malfunctioning parts.

#### 2. CHECK REAR SUNSHADE SWITCH

Check rear sunshade switch.

Refer to [INT-17, "Component Function Check"](#).

Is the inspection result normal?

YES >> GO TO 3.

NO >> Repair or replace the malfunctioning parts.

#### 3. CONFIRM THE OPERATION

Check the operation again.

Is the result normal?

YES >> Check intermittent incident. Refer to [GI-41, "Intermittent Incident"](#).

NO >> GO TO 1.

A  
B  
C  
D  
E  
F  
G  
H  
I  
K  
L  
M  
N  
O  
P

INT

# SQUEAK AND RATTLE TROUBLE DIAGNOSES

< SYMPTOM DIAGNOSIS >

## SQUEAK AND RATTLE TROUBLE DIAGNOSES

### Work Flow

INFOID:000000011933611

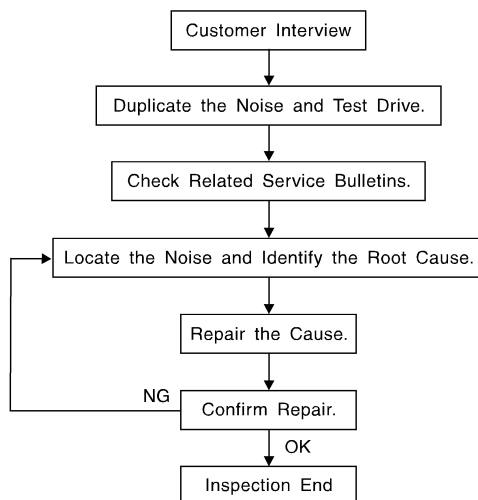

SBT842

### CUSTOMER INTERVIEW

Interview the customer if possible, to determine the conditions that exist when the noise occurs. Use the Diagnostic Worksheet during the interview to document the facts and conditions when the noise occurs and any customer's comments; refer to [INT-24, "Diagnostic Worksheet"](#). This information is necessary to duplicate the conditions that exist when the noise occurs.

- The customer may not be able to provide a detailed description or the location of the noise. Attempt to obtain all the facts and conditions that exist when the noise occurs (or does not occur).
- If there is more than one noise in the vehicle, be sure to diagnose and repair the noise that the customer is concerned about. This can be accomplished by test driving the vehicle with the customer.
- After identifying the type of noise, isolate the noise in terms of its characteristics. The noise characteristics are provided so the customer, service adviser and technician are all speaking the same language when defining the noise.
- Squeak —(Like tennis shoes on a clean floor)  
Squeak characteristics include the light contact/fast movement/brought on by road conditions/hard surfaces = higher pitch noise/softer surfaces = lower pitch noises/edge to surface = chirping.
- Creak—(Like walking on an old wooden floor)  
Creak characteristics include firm contact/slow movement/twisting with a rotational movement/pitch dependent on materials/often brought on by activity.
- Rattle—(Like shaking a baby rattle)  
Rattle characteristics include the fast repeated contact/vibration or similar movement/loose parts/missing clip or fastener/incorrect clearance.
- Knock —(Like a knock on a door)  
Knock characteristics include hollow sounding/sometimes repeating/often brought on by driver action.
- Tick—(Like a clock second hand)  
Tick characteristics include gentle contacting of light materials/loose components/can be caused by driver action or road conditions.
- Thump—(Heavy, muffled knock noise)  
Thump characteristics include softer knock/dead sound often brought on by activity.
- Buzz—(Like a bumble bee)  
Buzz characteristics include high frequency rattle/firm contact.
- Often the degree of acceptable noise level will vary depending upon the person. A noise that you may judge as acceptable may be very irritating to the customer.
- Weather conditions, especially humidity and temperature, may have a great effect on noise level.

### DUPLICATE THE NOISE AND TEST DRIVE

If possible, drive the vehicle with the customer until the noise is duplicated. Note any additional information on the Diagnostic Worksheet regarding the conditions or location of the noise. This information can be used to duplicate the same conditions when you confirm the repair.

# SQUEAK AND RATTLE TROUBLE DIAGNOSES

## < SYMPTOM DIAGNOSIS >

If the noise can be duplicated easily during the test drive, to help identify the source of the noise, try to duplicate the noise with the vehicle stopped by doing one or all of the following:

- 1) Close a door.
  - 2) Tap or push/pull around the area where the noise appears to be coming from.
  - 3) Rev the engine.
  - 4) Use a floor jack to recreate vehicle "twist".
  - 5) At idle, apply engine load (electrical load, half-clutch on M/T model, drive position on CVT and A/T models).
  - 6) Raise the vehicle on a hoist and hit a tire with a rubber hammer.
- Drive the vehicle and attempt to duplicate the conditions the customer states exist when the noise occurs.
  - If it is difficult to duplicate the noise, drive the vehicle slowly on an undulating or rough road to stress the vehicle body.

## CHECK RELATED SERVICE BULLETINS

After verifying the customer concern or symptom, check ASIST for Technical Service Bulletins (TSBs) related to that concern or symptom.

If a TSB relates to the symptom, follow the procedure to repair the noise.

## LOCATE THE NOISE AND IDENTIFY THE ROOT CAUSE

1. Narrow down the noise to a general area. To help pinpoint the source of the noise, use a listening tool (Chassis Ear: J-39570, Engine Ear: J-39565 and mechanic's stethoscope).
2. Narrow down the noise to a more specific area and identify the cause of the noise by:
  - removing the components in the area that you suspect the noise is coming from.  
Do not use too much force when removing clips and fasteners, otherwise clips and fasteners can be broken or lost during the repair, resulting in the creation of new noise.
  - tapping or pushing/pulling the component that you suspect is causing the noise.  
Do not tap or push/pull the component with excessive force, otherwise the noise will be eliminated only temporarily.
  - feeling for a vibration with your hand by touching the component(s) that you suspect is (are) causing the noise.
  - placing a piece of paper between components that you suspect are causing the noise.
  - looking for loose components and contact marks.Refer to [INT-21. "Generic Squeak and Rattle Troubleshooting"](#).

## REPAIR THE CAUSE

- If the cause is a loose component, tighten the component securely.
- If the cause is insufficient clearance between components:
  - separate components by repositioning or loosening and retightening the component, if possible.
  - insulate components with a suitable insulator such as urethane pads, foam blocks, felt cloth tape or urethane tape. A NISSAN Squeak and Rattle Kit (J-50397) is available through your authorized NISSAN Parts Department.

### **CAUTION:**

**Do not use excessive force as many components are constructed of plastic and may be damaged.**

### **NOTE:**

- Always check with the Parts Department for the latest parts information.
- The materials contained in the NISSAN Squeak and Rattle Kit (J-50397) are listed on the inside cover of the kit; and can each be ordered separately as needed.
- The following materials not found in the kit can also be used to repair squeaks and rattles.
  - SILICONE GREASE: Use instead of UHMW tape that will be visible or does not fit. The silicone grease will only last a few months.
  - SILICONE SPRAY: Use when grease cannot be applied.
  - DUCT TAPE: Use to eliminate movement.

## CONFIRM THE REPAIR

Confirm that the cause of a noise is repaired by test driving the vehicle. Operate the vehicle under the same conditions as when the noise originally occurred. Refer to the notes on the Diagnostic Worksheet.

## Generic Squeak and Rattle Troubleshooting

INFOID:000000011933612

Refer to Table of Contents for specific component removal and installation information.

## INSTRUMENT PANEL

Most incidents are caused by contact and movement between:

# SQUEAK AND RATTLE TROUBLE DIAGNOSES

## < SYMPTOM DIAGNOSIS >

---

1. Cluster lid A and the instrument panel
2. Acrylic lens and combination meter housing
3. Instrument panel to front pillar finisher
4. Instrument panel to windshield
5. Instrument panel pins
6. Wiring harnesses behind the combination meter
7. A/C defroster duct and duct joint

These incidents can usually be located by tapping or moving the components to duplicate the noise or by pressing on the components while driving to stop the noise. Most of these incidents can be repaired by applying felt cloth tape or silicone spray (in hard to reach areas). Urethane pads can be used to insulate wiring harness.

### **CAUTION:**

**Do not use silicone spray to isolate a squeak or rattle. If you saturate the area with silicone, you will not be able to recheck the repair.**

## CENTER CONSOLE

Components to pay attention to include:

1. Shift selector assembly cover to finisher
2. A/C control unit and cluster lid C
3. Wiring harnesses behind audio and A/C control unit

The instrument panel repair and isolation procedures also apply to the center console.

## DOORS

Pay attention to the:

1. Finisher and inner panel making a slapping noise
2. Inside handle escutcheon to door finisher
3. Wiring harnesses tapping
4. Door striker out of alignment causing a popping noise on starts and stops

Tapping or moving the components or pressing on them while driving to duplicate the conditions can isolate many of these incidents. You can usually insulate the areas with felt cloth tape or insulator foam blocks from the NISSAN Squeak and Rattle Kit (J-50397) to repair the noise.

## TRUNK

Trunk noises are often caused by a loose jack or loose items put into the trunk by the owner.

In addition look for:

1. Trunk lid bumpers out of adjustment
2. Trunk lid striker out of adjustment
3. The trunk lid torsion bars knocking together
4. A loose license plate or bracket

Most of these incidents can be repaired by adjusting, securing or insulating the item(s) or component(s) causing the noise.

## SUNROOF/HEADLINING

Noises in the sunroof/headlining area can often be traced to one of the following:

1. Sunroof lid, rail, linkage or seals making a rattle or light knocking noise
2. Sun visor shaft shaking in the holder
3. Front or rear windshield touching headlining and squeaking

Again, pressing on the components to stop the noise while duplicating the conditions can isolate most of these incidents. Repairs usually consist of insulating with felt cloth tape.

## OVERHEAD CONSOLE (FRONT AND REAR)

Overhead console noises are often caused by the console panel clips not being engaged correctly. Most of these incidents are repaired by pushing up on the console at the clip locations until the clips engage.

In addition look for:

1. Loose harness or harness connectors.
2. Front console map/reading lamp lens loose.

# SQUEAK AND RATTLE TROUBLE DIAGNOSES

## < SYMPTOM DIAGNOSIS >

---

3. Loose screws at console attachment points.

### SEATS

When isolating seat noise it's important to note the position the seat is in and the load placed on the seat when the noise is present. These conditions should be duplicated when verifying and isolating the cause of the noise.

Cause of seat noise include:

1. Headrest rods and holder
2. A squeak between the seat pad cushion and frame
3. The rear seatback lock and bracket

These noises can be isolated by moving or pressing on the suspected components while duplicating the conditions under which the noise occurs. Most of these incidents can be repaired by repositioning the component or applying urethane tape to the contact area.

### UNDERHOOD

Some interior noise may be caused by components under the hood or on the engine wall. The noise is then transmitted into the passenger compartment.

Causes of transmitted underhood noise include:

1. Any component installed to the engine wall
2. Components that pass through the engine wall
3. Engine wall mounts and connectors
4. Loose radiator installation pins
5. Hood bumpers out of adjustment
6. Hood striker out of adjustment

These noises can be difficult to isolate since they cannot be reached from the interior of the vehicle. The best method is to secure, move or insulate one component at a time and test drive the vehicle. Also, engine rpm or load can be changed to isolate the noise. Repairs can usually be made by moving, adjusting, securing, or insulating the component causing the noise.

A  
B  
C  
D  
E  
F  
G  
H  
I  
K  
L  
M  
N  
O  
P

INT

# SQUEAK AND RATTLE TROUBLE DIAGNOSES

< SYMPTOM DIAGNOSIS >

## Diagnostic Worksheet

INFOID:000000011933613

Dear Customer:

We are concerned about your satisfaction with your vehicle. Repairing a squeak or rattle sometimes can be very difficult. To help us fix your vehicle right the first time, please take a moment to note the area of the vehicle where the squeak or rattle occurs and under what conditions. You may be asked to take a test drive with a service advisor or technician to ensure we confirm the noise you are hearing.

### SQUEAK & RATTLE DIAGNOSTIC WORKSHEET

#### I. WHERE DOES THE NOISE COME FROM? (circle the area of the vehicle)

The illustrations are for reference only, and may not reflect the actual configuration of your vehicle.

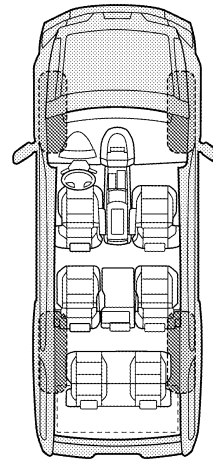
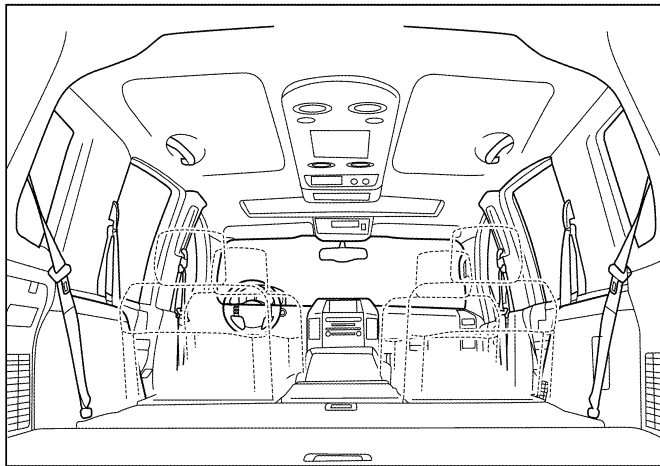
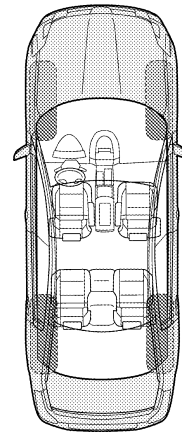
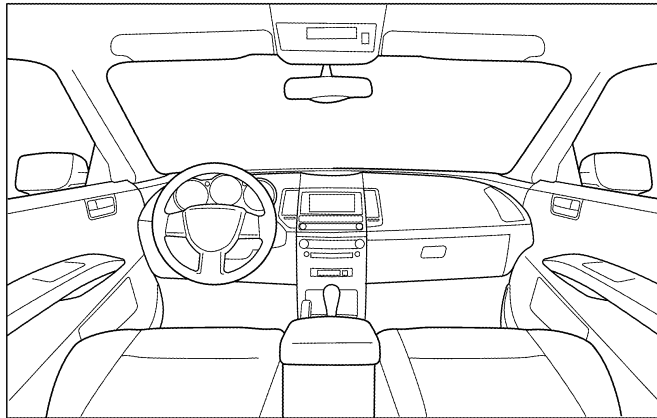

Continue to page 2 of the worksheet and briefly describe the location of the noise or rattle. In addition, please indicate the conditions which are present when the noise occurs.



# SQUEAK AND RATTLE TROUBLE DIAGNOSES

< SYMPTOM DIAGNOSIS >

## SQUEAK & RATTLE DIAGNOSTIC WORKSHEET - page 2

Briefly describe the location where the noise occurs:

\_\_\_\_\_

\_\_\_\_\_

### II. WHEN DOES IT OCCUR? (please check the boxes that apply)

- |   |  |
|---|--|
| <input type="checkbox"/> Anytime                      | <input type="checkbox"/> After sitting out in the rain |
| <input type="checkbox"/> 1st time in the morning      | <input type="checkbox"/> When it is raining or wet     |
| <input type="checkbox"/> Only when it is cold outside | <input type="checkbox"/> Dry or dusty conditions       |
| <input type="checkbox"/> Only when it is hot outside  | <input type="checkbox"/> Other:                        |

### III. WHEN DRIVING:

- Through driveways
- Over rough roads
- Over speed bumps
- Only about \_\_\_\_ mph
- On acceleration
- Coming to a stop
- On turns: left, right or either (circle)
- With passengers or cargo
- Other: \_\_\_\_\_
- After driving \_\_\_\_ miles or \_\_\_\_ minutes

### IV. WHAT TYPE OF NOISE

- Squeak (like tennis shoes on a clean floor)
- Creak (like walking on an old wooden floor)
- Rattle (like shaking a baby rattle)
- Knock (like a knock at the door)
- Tick (like a clock second hand)
- Thump (heavy muffled knock noise)
- Buzz (like a bumble bee)

### TO BE COMPLETED BY DEALERSHIP PERSONNEL

Test Drive Notes:

\_\_\_\_\_

\_\_\_\_\_

\_\_\_\_\_

	YES	NO	Initials of person performing
Vehicle test driven with customer	<input type="checkbox"/>	<input type="checkbox"/>	_____
- Noise verified on test drive	<input type="checkbox"/>	<input type="checkbox"/>	_____
- Noise source located and repaired	<input type="checkbox"/>	<input type="checkbox"/>	_____
- Follow up test drive performed to confirm repair	<input type="checkbox"/>	<input type="checkbox"/>	_____

VIN: \_\_\_\_\_ Customer Name \_\_\_\_\_

W.O.# \_\_\_\_\_ Date: \_\_\_\_\_

This form must be attached to Work Order

LAI/A0071E

A  
B  
C  
D  
E  
F  
G  
H  
I  
**INT**  
K  
L  
M  
N  
O  
P

# FRONT DOOR FINISHER

< REMOVAL AND INSTALLATION >

## REMOVAL AND INSTALLATION

### FRONT DOOR FINISHER

Exploded View

INFOID:000000011933619

**NOTE:**

LH side shown.

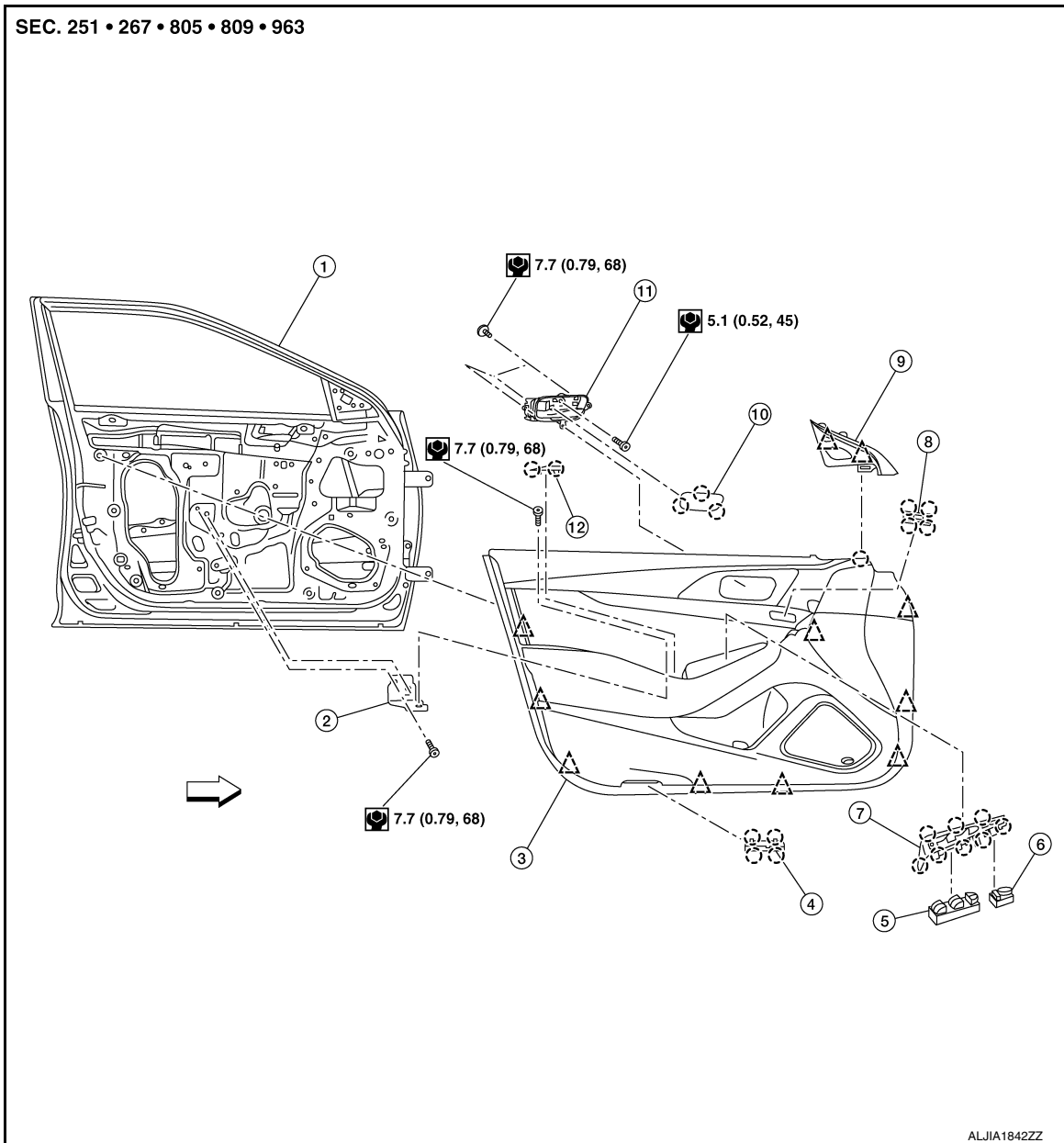

- |   |  |                                      |
|---|--|--------------------------------------|
| 1. Front door panel                                       | 2. Front door finisher bracket                   | 3. Front door finisher               |
| 4. Step lamp  | 5. Main power window and door lock/unlock switch | 6. Door mirror remote control switch |
| 7. Main power window and door lock/unlock switch finisher | 8. Seat memory switch (if equipped)              | 9. Front door mirror corner cover    |
| 10. Inside door handle escutcheon                         | 11. Inside door handle                           | 12. Front door pull handle cover     |
- Pawl     
 Clip     
 Front

# FRONT DOOR FINISHER

## < REMOVAL AND INSTALLATION >

### Removal and Installation

INFOID:000000011933620

#### REMOVAL

##### NOTE:

LH side shown.

1. Using suitable tool, release pawls and remove inside door handle escutcheon (1).

 : Pawl

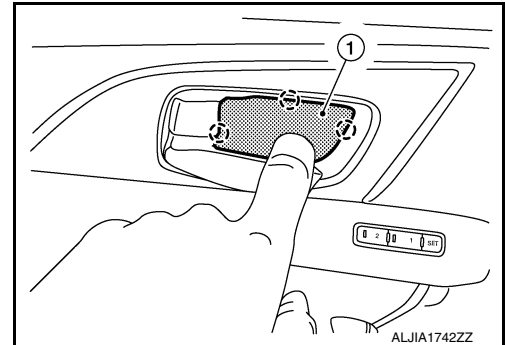

2. Remove bolt from inside door handle.
3. Using suitable tool, release pawls and remove front door pull handle cover (1).

 : Pawl

 : Front

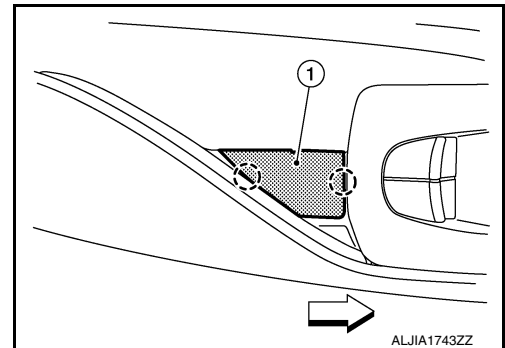

4. Remove front door pull handle screw (A).

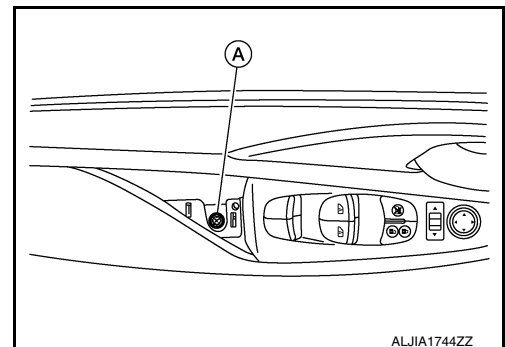

5. Remove main power window and door lock/unlock switch (LH) or power window and door lock/unlock switch (RH) and finisher as an assembly. Refer to [PWC-67, "Removal and Installation" \(MAIN\)](#) or [PWC-68, "Removal and Installation" \(RH\)](#).
6. Using suitable tool, release clips and pawl then remove front door finisher as shown.

 : Pawl

 : Clip

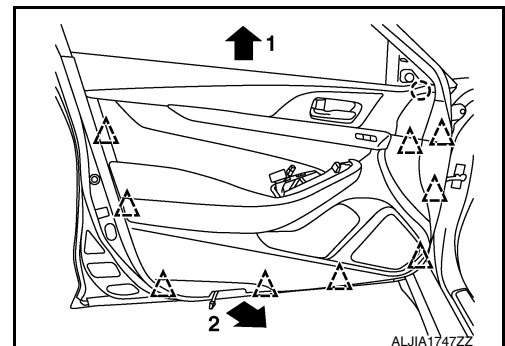

7. Disconnect harness connector from seat memory switch (if equipped).
8. Disconnect door lock cable and inside handle cable from front door finisher.

A  
B  
C  
D  
E  
F  
G  
H  
I  
INT  
K  
L  
M  
N  
O  
P

## FRONT DOOR FINISHER

### < REMOVAL AND INSTALLATION >

9. Disconnect harness connector from front door armrest mood lamp (if equipped).
10. Remove front door finisher.
11. If necessary, remove front step lamp. Refer to [INL-54, "Removal and Installation"](#).
12. If necessary, remove front door finisher bracket bolts and front door finisher bracket.

### INSTALLATION

1. Install front door finisher bracket in sequence shown.

↩ : Front

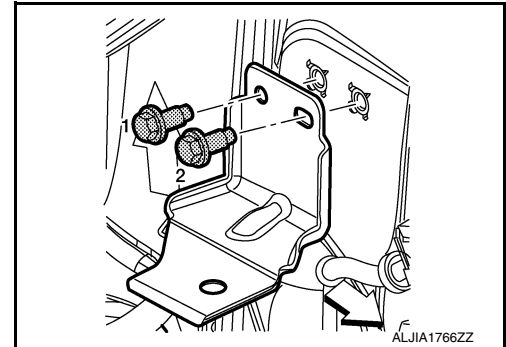

2. Installation of the remaining components are in the reverse order of removal.

#### **CAUTION:**

- Visually check clips and pawls for deformation and damage during installation. Replace if necessary.
- Before installing front door finisher clips, align to front door by starting from top front and working rearward.
- When installing front door finisher, check that clips are securely placed in body panel holes.
- Install front door inside handle bolt and screw before installing remaining components.

#### **NOTE:**

When main power window and door lock/unlock switch is removed or replaced, it is necessary to perform initialization procedure. Refer to [PWC-30, "Description"](#).

# REAR DOOR FINISHER

< REMOVAL AND INSTALLATION >

## REAR DOOR FINISHER

### Exploded View

INFOID:000000011933621

**NOTE:**

LH side shown.

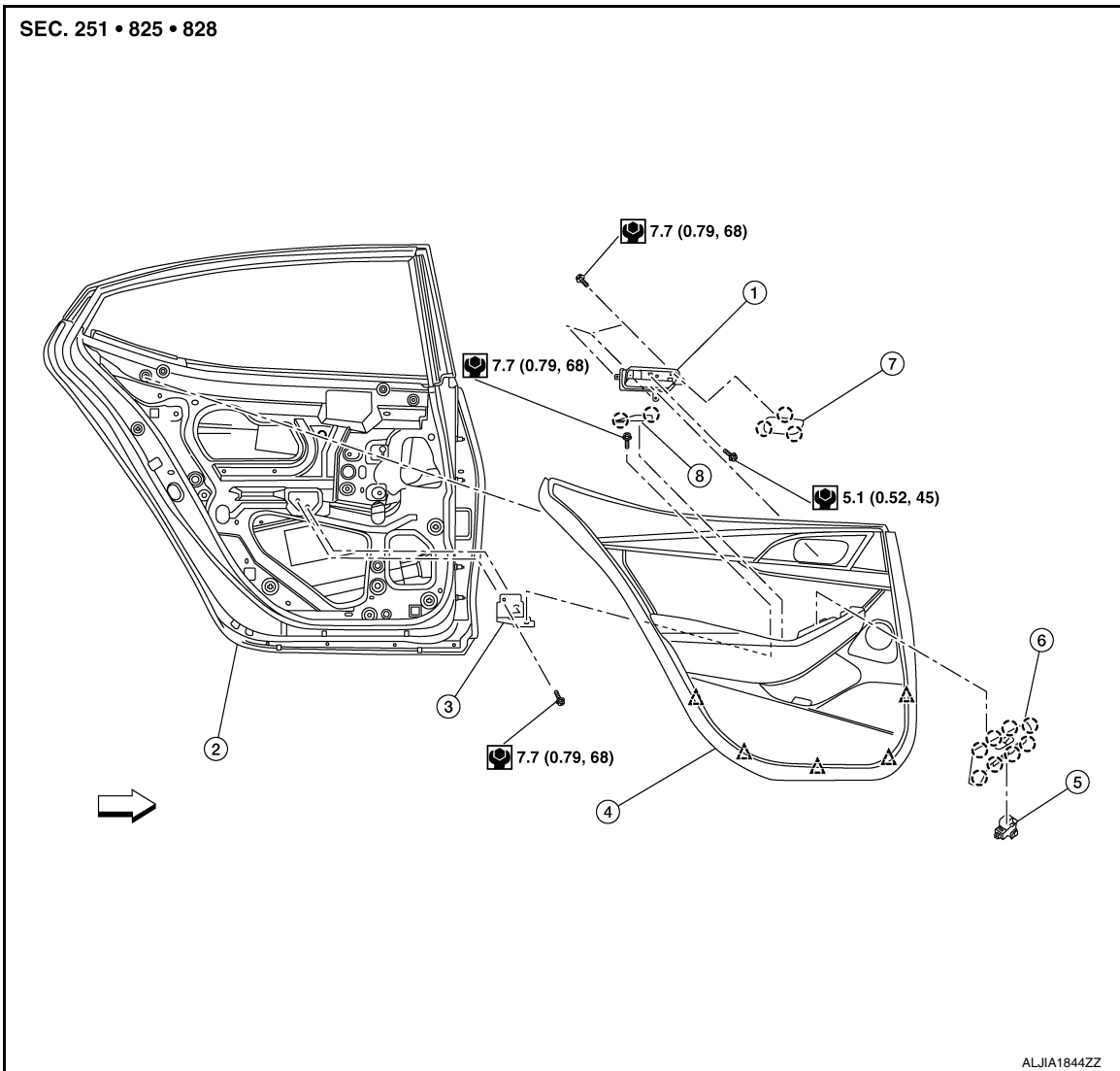

- |                                       |                                |                                      |
|---------------------------------------|--------------------------------|--------------------------------------|
| 1. Rear door inside handle            | 2. Rear door panel             | 3. Rear door finisher bracket        |
| 4. Rear door finisher                 | 5. Rear power window switch    | 6. Rear power window switch finisher |
| 7. Rear door inside handle escutcheon | 8. Rear door pull handle cover | △ Clip                               |
- Pawl      ⇐ Front

### Removal and Installation

INFOID:000000011933622

**REMOVAL**

**CAUTION:**

Wrap the tip of a suitable tool with a cloth when removing metal clips from finishers.

**NOTE:**

LH side shown.

A  
B  
C  
D  
E  
F  
G  
H  
I  
INT  
K  
L  
M  
N  
O  
P

## REAR DOOR FINISHER

### < REMOVAL AND INSTALLATION >

1. Using a suitable tool, release pawls and remove rear door inside handle escutcheon (1).

 : Pawl

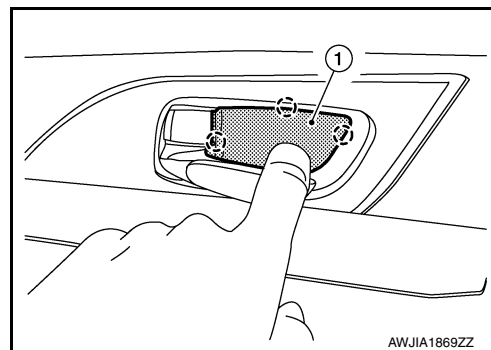

2. Remove bolt from rear door inside handle.
3. Using a suitable tool, release pawls and remove rear door pull handle cover (1).

 : Pawl

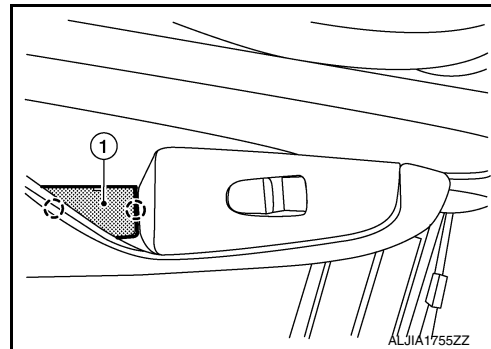

4. Remove rear door pull handle screw (A).

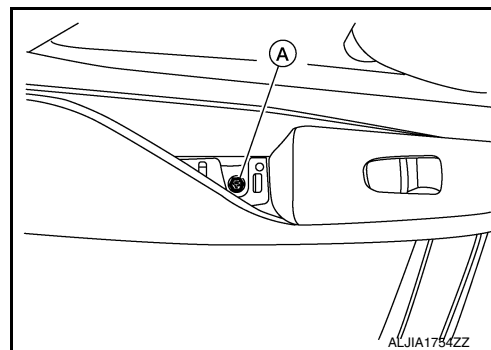

5. Using a suitable tool, release clips then remove rear door finisher as shown.

 : Clip

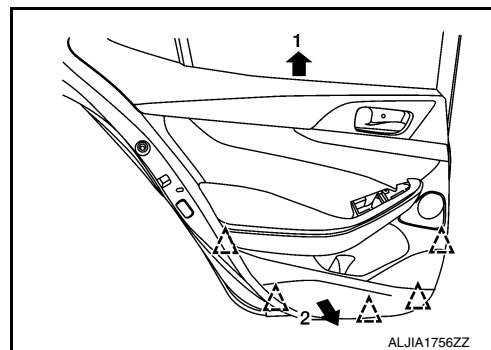

6. Disconnect door lock cable and inside handle cable from rear door inside handle.
7. Disconnect harness connector from the rear power window switch.

# REAR DOOR FINISHER

## < REMOVAL AND INSTALLATION >

8. Release rear door speaker harness clip from rear door finisher and disconnect harness connector from rear door speaker.

 : Clip

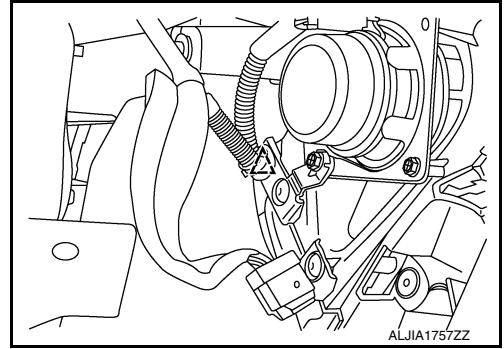

9. Remove rear door finisher.
10. If necessary, remove rear power window switch and rear power window switch finisher as an assembly. Refer to [PWC-69. "Removal and Installation"](#).
11. If necessary, remove rear door finisher bracket bolts and rear door finisher bracket.

## INSTALLATION

1. Install rear door finisher bracket in sequence shown.

 : Front

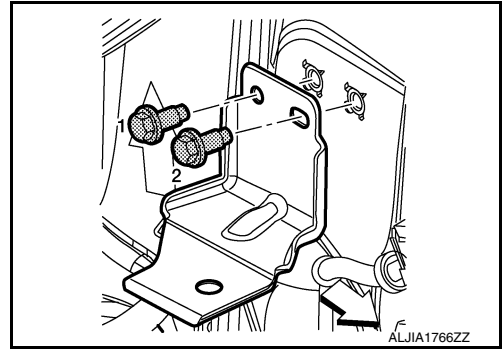

2. Installation of the remaining components are in the reverse order of removal.

### **CAUTION:**

- Visually check clips and pawls for deformation and damage during installation. Replace if necessary.
- When installing rear door finisher, install clips starting from top front and working rearward.
- When installing rear door finisher, check that clips are securely placed in body panel holes.

A  
B  
C  
D  
E  
F  
G  
H  
I  
INT  
K  
L  
M  
N  
O  
P

# BODY SIDE TRIM

< REMOVAL AND INSTALLATION >

## BODY SIDE TRIM

Exploded View

INFOID:000000011933623

**NOTE:**

LH side shown.

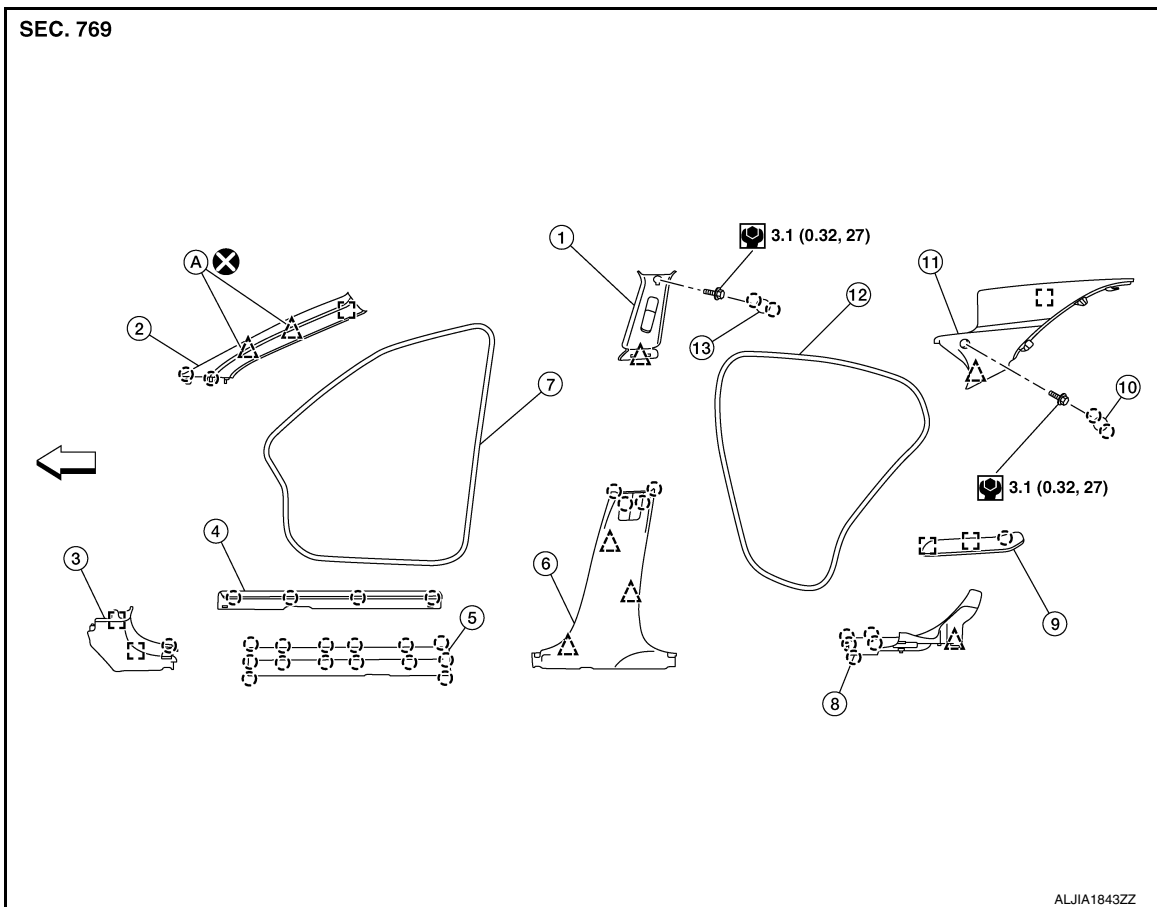

- |  |                              |                                 |
|--|------------------------------|---------------------------------|
| 1. Center pillar upper finisher        | 2. Front pillar finisher     | 3. Dash side finisher           |
| 4. Front kicking plate outer           | 5. Front kicking plate inner | 6. Center pillar lower finisher |
| 7. Front body side welt                | 8. Rear kicking plate inner  | 9. Rear kicking plate outer     |
| 10. Rear pillar finisher cover         | 11. Rear pillar finisher     | 12. Rear body side welt         |
| 13. Center pillar upper finisher cover | A. Tether clip               | △ Clip                          |
| ○ Pawl                                 | □ Metal clip                 | ⇐ Front                         |

## DASH SIDE FINISHER

### DASH SIDE FINISHER : Removal and Installation

INFOID:000000011933624

#### REMOVAL

1. Remove front kicking plate inner. Refer to [INT-34. "FRONT KICKING PLATE : Removal and Installation - Inner"](#).



# BODY SIDE TRIM

## < REMOVAL AND INSTALLATION >

- Using a suitable tool, release metal clips, then remove dash side finisher.

 : Metal clip

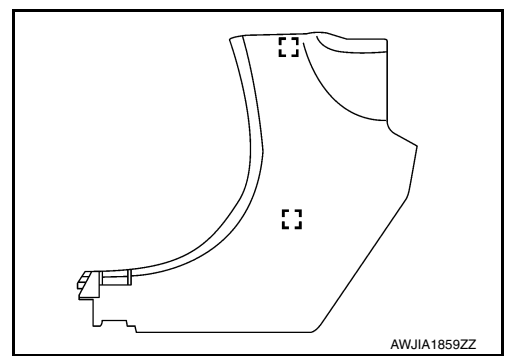

### INSTALLATION

Installation is in the reverse order of removal.

#### CAUTION:

- Visually check the metal clips for deformation and damage during installation. Replace as necessary.
- When installing the dash side finisher, check that the metal clips are securely placed in the body panel holes.

### FRONT PILLAR FINISHER

#### FRONT PILLAR FINISHER : Removal and Installation

INFOID:000000012203283

### REMOVAL

- Partially remove front body side welt. Refer to [INT-36, "BODY SIDE WELT : Removal and Installation - Front"](#).
- Using a suitable tool, release front pillar finisher (1) metal clip.

 : Metal clip

- Release front pillar finisher tether clips using following steps:

#### CAUTION:

**Do not reuse tether clips.**

 : Tether clip

 : Pawl

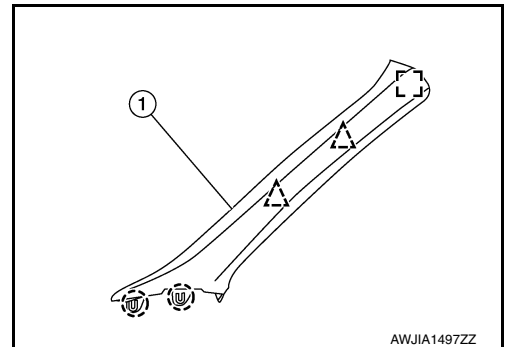

- Insert a suitable tool (A) between the front pillar finisher bottom side and body side to release the tether clip.

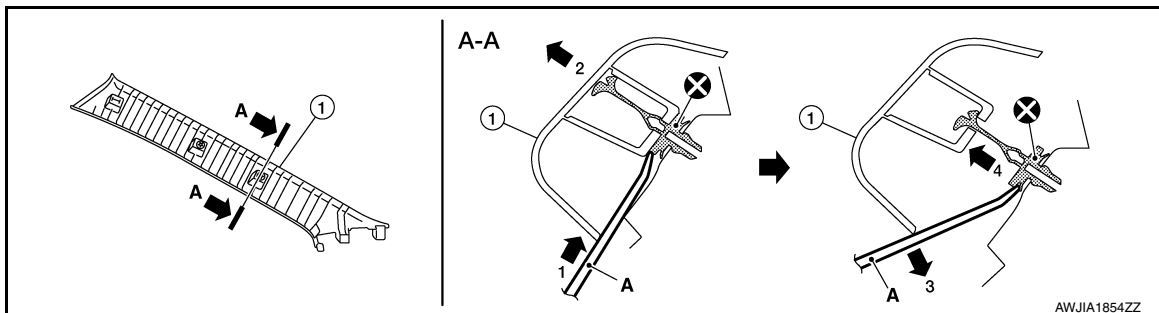

- Pull front pillar finisher upward and use a suitable tool to cut both tether clips.
- Remove front pillar finisher (1).

### INSTALLATION

Installation is in the reverse order of removal.

#### CAUTION:

- Do not reuse tether clips.
- Visually check the metal clip and pawls for deformation and damage during installation. Replace if necessary.

# BODY SIDE TRIM

## < REMOVAL AND INSTALLATION >

- When installing the front pillar finisher, check that the metal clip, tether clips and pawls are securely placed in the body panel holes.

### FRONT KICKING PLATE

#### FRONT KICKING PLATE : Removal and Installation - Inner

INFOID:000000012203284

##### REMOVAL

1. Using a suitable tool, release front kicking plate inner (1) pawls and remove.

- : Pawl  
⇐ : Front

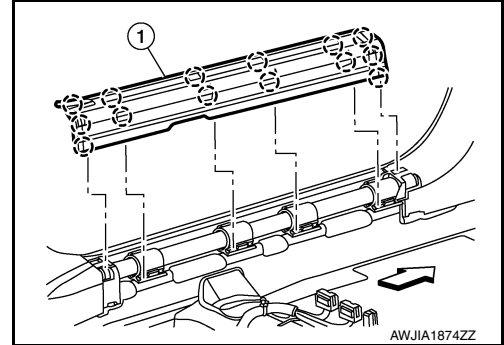

##### INSTALLATION

Installation is in the reverse order of removal.

##### **CAUTION:**

**When installing the front kicking plate inner, check that the pawls are securely placed in the body panel holes.**

#### FRONT KICKING PLATE : Removal and Installation - Outer

INFOID:000000012203285

##### REMOVAL

1. Using a suitable tool, release metal clips and pawls, then remove front kicking plate outer.

- : Pawl  
⇐ : Front

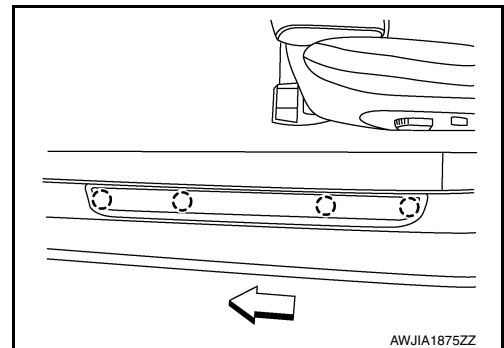

##### INSTALLATION

Installation is in the reverse order of removal.

##### **CAUTION:**

**When installing the front kicking plate outer, check that the pawls are securely placed in the body panel holes.**

### REAR KICKING PLATE

#### REAR KICKING PLATE : Removal and Installation - Inner

INFOID:000000012203286

##### REMOVAL

1. Remove rear seat cushion. Refer to [SE-89, "Removal and Installation"](#).

## BODY SIDE TRIM

### < REMOVAL AND INSTALLATION >

- Using suitable tool, release rear kicking plate inner pawls and clip.

**NOTE:**

RH shown; LH similar.

-  : Clip
-  : Pawl
-  : Front

- Release rear kicking plate inner (1) from metal clips (A), then remove.

**NOTE:**

Take note of metal clip locations on body side flange for ease of installation.

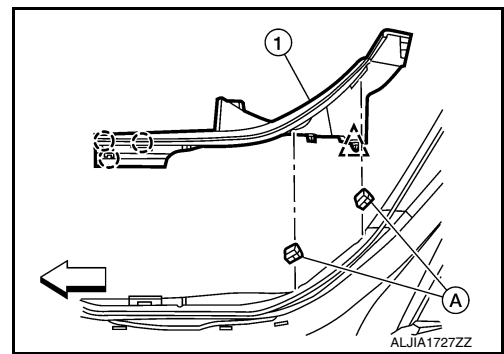

### INSTALLATION

- Install rear kicking plate inner using the following procedure:

- Install metal clip (A) on body side flange.
- Install metal clip (B) on body side flange.
- Install the front most pawls (C) to the center pillar finisher.
- Install pawls (D) to body panel.
- Install rear kicking plate to metal clip (A).
- Install rear kicking plate to metal clip (C).
- Install clip (E).

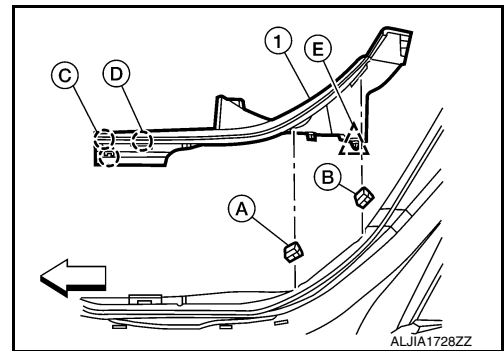

- Installation of the remaining parts are in the reverse order of removal.

**CAUTION:**



- If metal clip is removed from the sheet metal, replace metal clip with a new part.
- Visually check the clips for deformation and damage during installation. Replace as necessary.
- When installing the rear kicking plate inner, check that the clip and pawls are securely placed in the body panel holes.

### REAR KICKING PLATE : Removal and Installation - Outer

INFOID:000000012203287

#### REMOVAL

- Using a suitable tool, release molded in clips and pawls, then remove rear kicking plate outer (1).

-  : Pawl
-  : Molded in clip
-  : Front

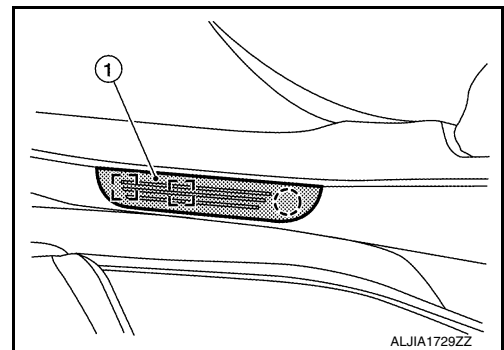

#### INSTALLATION

Installation is in the reverse order of removal.

**CAUTION:**

- When installing the rear kicking plate outer, check that the molded in clips and pawls are securely placed in the body panel holes.

### BODY SIDE WELT

## BODY SIDE TRIM

< REMOVAL AND INSTALLATION >

### BODY SIDE WELT : Removal and Installation - Front

INFOID:000000012203294

#### REMOVAL

1. Remove instrument side finisher. Refer to [JP-14, "Exploded View"](#).
2. Remove center pillar lower finisher. Refer to [INT-36, "CENTER PILLAR LOWER FINISHER : Removal and Installation"](#).
3. Remove front body side welt.

#### INSTALLATION

Installation is in the reverse order of removal.

### BODY SIDE WELT : Removal and Installation - Rear

INFOID:000000012203295

#### REMOVAL

1. Remove center pillar lower finisher. Refer to [INT-36, "CENTER PILLAR LOWER FINISHER : Removal and Installation"](#).
2. Remove rear body side welt.

#### INSTALLATION

Installation is in the reverse order of removal.

### CENTER PILLAR LOWER FINISHER

#### CENTER PILLAR LOWER FINISHER : Removal and Installation

INFOID:000000012203296

#### REMOVAL

1. Move front seat to fully forward position.
2. Remove front kicking plate inner. Refer to [INT-34, "FRONT KICKING PLATE : Removal and Installation - Inner"](#).
3. Remove rear kicking plate inner. Refer to [INT-34, "REAR KICKING PLATE : Removal and Installation - Inner"](#).
4. Partially remove front and rear body side welt.
5. Using a suitable tool, release clips and pawls.

- : Pawl
- △ : Clip
- ⇐ : Front

#### NOTE:

RH shown, LH similar.

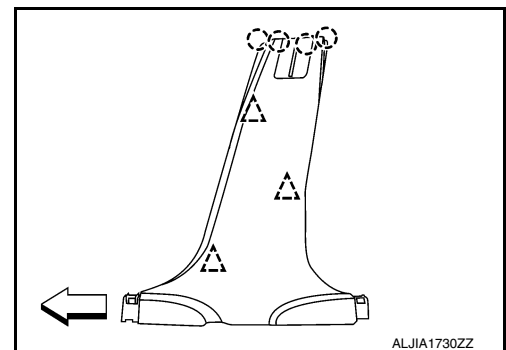

6. Remove seat belt from center pillar lower finisher, then remove center pillar lower finisher.

#### INSTALLATION

Installation is in the reverse order of removal.

#### CAUTION:

- Visually check the clips for deformation and damage during installation. Replace if necessary.
- When installing the center pillar lower finisher, check that the clips are securely placed in the body panel holes.

### CENTER PILLAR UPPER FINISHER

#### CENTER PILLAR UPPER FINISHER : Removal and Installation

INFOID:000000012203297

#### REMOVAL

# BODY SIDE TRIM

## < REMOVAL AND INSTALLATION >

1. Remove center pillar lower finisher. Refer to [INT-36, "CENTER PILLAR LOWER FINISHER : Removal and Installation"](#).
2. Remove seat belt bolt cover (1) and seat belt D-ring anchor bolt (A).

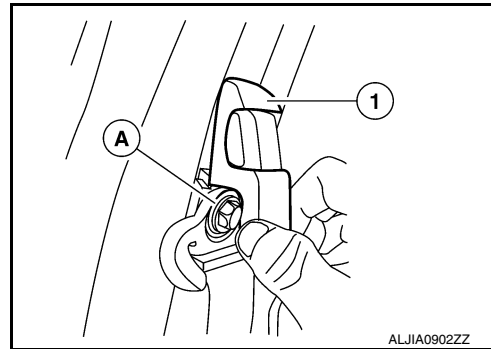

3. Release pawls and position center pillar upper finisher cover (1) aside, then remove bolt (A).

 : Pawl

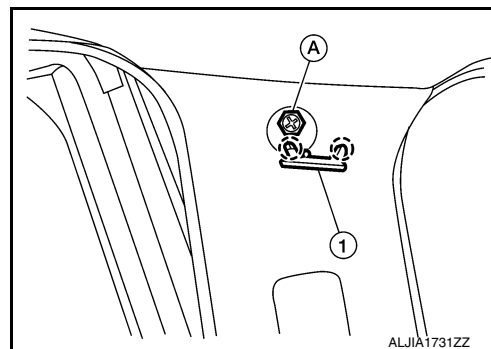

4. Using a suitable tool, release clip, then remove center pillar upper finisher.

 : Clip

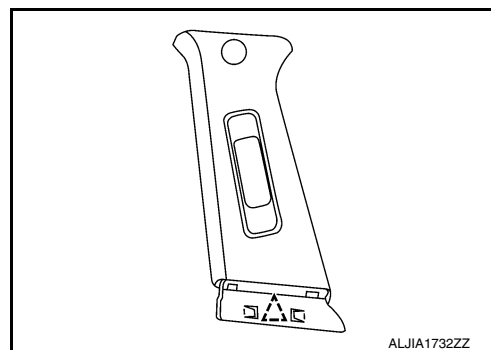

## INSTALLATION

Installation is in the reverse order of removal.

### **CAUTION:**

**When installing the center pillar upper finisher, check that the clip is securely placed in the body panel holes.**

## REAR PILLAR FINISHER

### REAR PILLAR FINISHER : Removal and Installation

INFOID:000000012203298

## REMOVAL

1. Remove rear seat bolster. Refer to [SE-93, "Removal and Installation - Rear Seat Bolster"](#).

## BODY SIDE TRIM

### < REMOVAL AND INSTALLATION >

- Using a suitable tool, release pawls and position rear pillar cover (1) aside, then remove screw.

 : Pawl

- Using a suitable tool, release clip, then release metal clip.

 : Metal clip

 : Clip

- Remove rear pillar finisher (2) in direction shown.

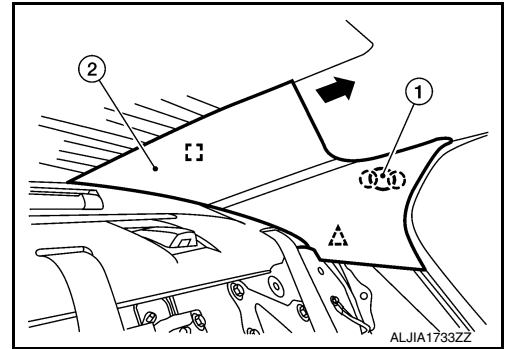

### INSTALLATION

Installation is in the reverse order of removal.

#### **CAUTION:**

- **Visually check the clips and metal clips for deformation and damage during installation. Replace if necessary.**
- **When installing the rear pillar finisher, check that the clips, metal clips, push pin and pawls are securely placed in the body panel holes.**

# REAR PARCEL SHELF FINISHER

< REMOVAL AND INSTALLATION >

## REAR PARCEL SHELF FINISHER

Exploded View

INFOID:000000011933625

WITH SUNSHADE

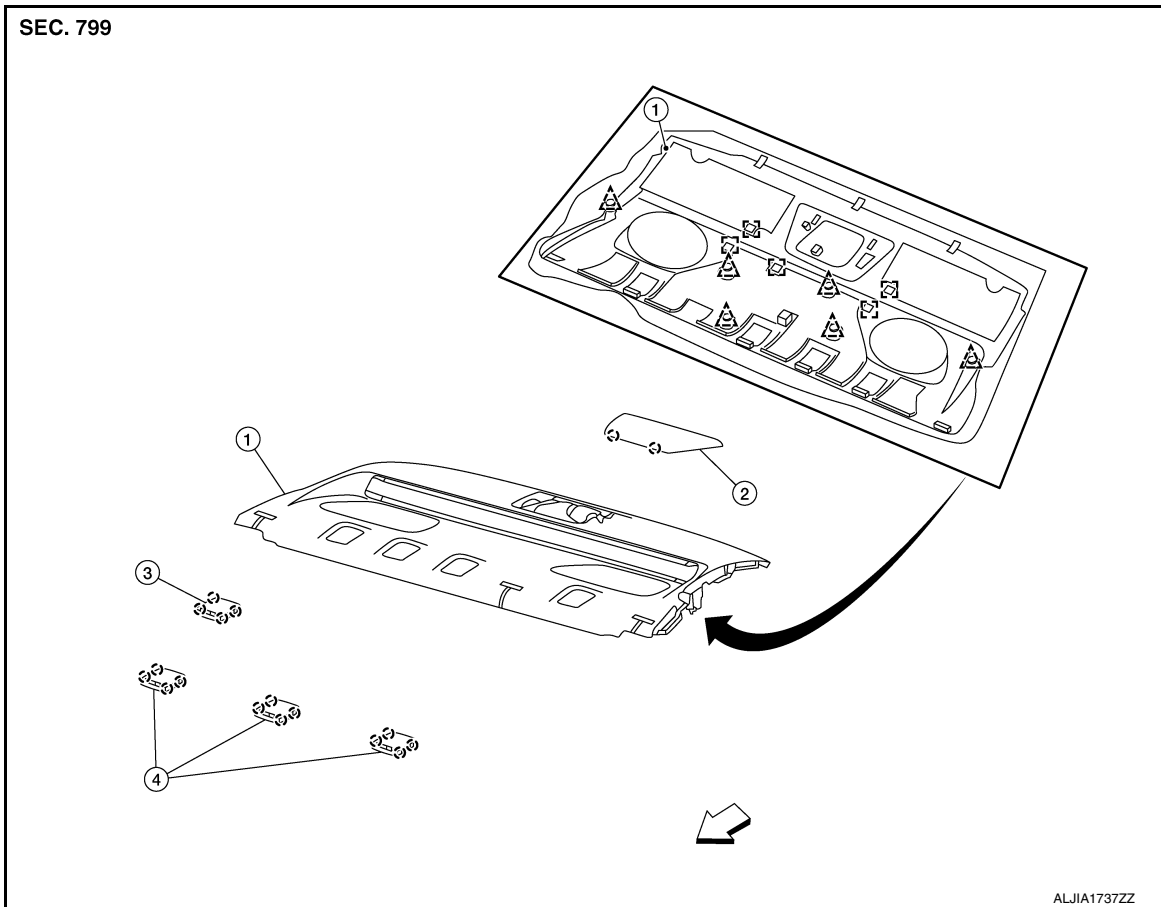

1. Rear parcel shelf finisher

4. Child anchor cover

[ ] Dual lock fasteners

2. High-mounted stop lamp

△ Clip

⇐ Front

3. Seatback lock finisher

○ Pawl

A  
B  
C  
D  
E  
F  
G  
H  
I  
INT  
K  
L  
M  
N  
O  
P

# REAR PARCEL SHELF FINISHER

< REMOVAL AND INSTALLATION >

WITHOUT SUNSHADE

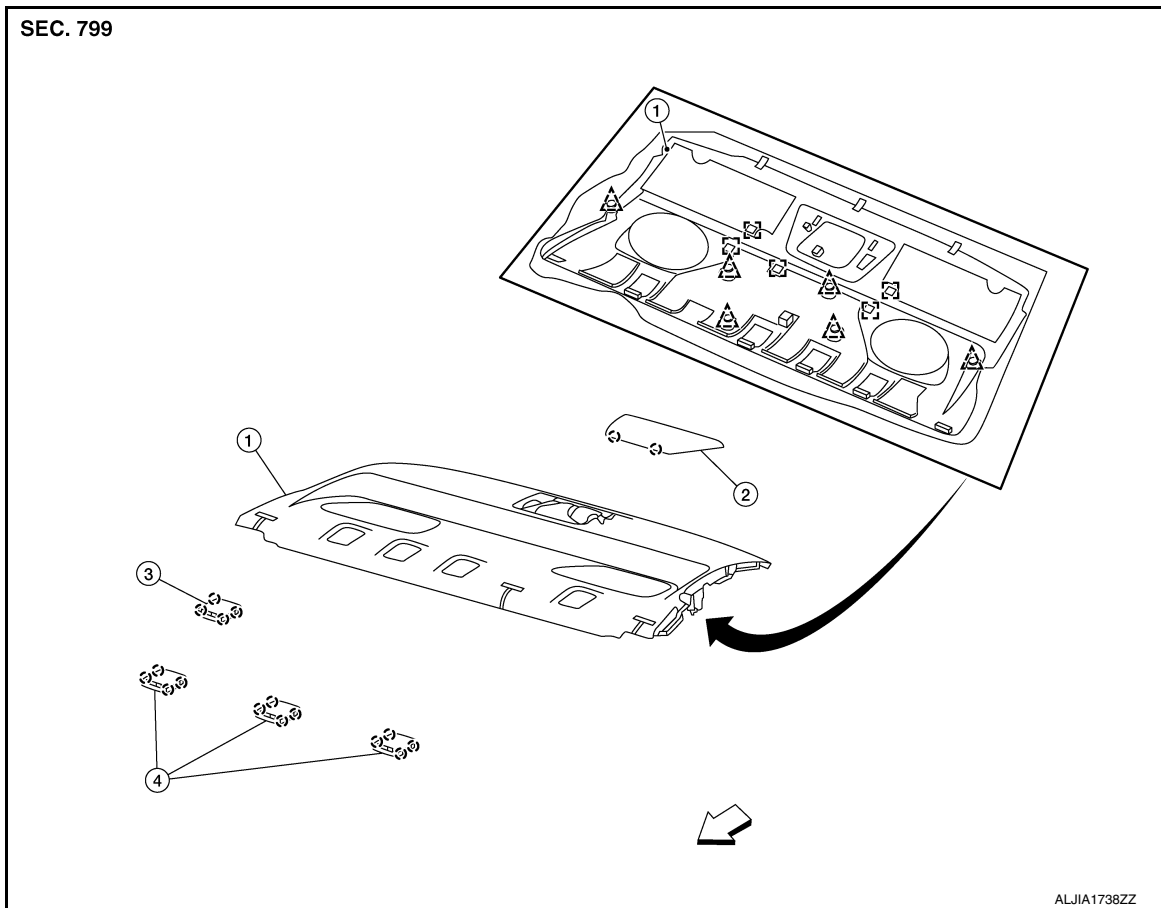

- |                               |                           |                           |
|-------------------------------|---------------------------|---------------------------|
| 1. Rear parcel shelf finisher | 2. High-mounted stop lamp | 3. Seatback lock finisher |
| 4. Child anchor cover         | △ Clip                    | ○ Pawl                    |
| [ ] Dual lock fasteners       | ← Front                   |                           |

## Removal and Installation

INFOID:000000011933626

### REMOVAL

1. Remove rear seatback assembly. Refer to [SE-89, "Removal and Installation"](#).
2. Remove rear kicking plate inners (LH/RH). Refer to [INT-34, "REAR KICKING PLATE : Removal and Installation - Inner"](#).
3. Remove high-mounted stop lamp. Refer to [EXL-119, "Removal and Installation"](#) (LED HEADLAMP) or [EXL-237, "Removal and Installation"](#) (HALOGEN HEADLAMP).
4. Remove rear pillar finishers (RH/LH). Refer to [INT-37, "REAR PILLAR FINISHER : Removal and Installation"](#).
5. Thread rear seat belts (RH/LH/center) through vertical opening and release from rear parcel shelf finisher.
6. Using a suitable tool, release clips and dual lock fasteners, then remove rear parcel shelf finisher.

### INSTALLATION

Installation is in the reverse order of removal.

#### CAUTION:

- Visually check clips for deformation and damage during installation. Replace with new ones if necessary.
- When installing rear parcel shelf finisher, check that clips and pawls are securely placed in body panel holes.



# REAR SUNSHADE

< REMOVAL AND INSTALLATION >

## REAR SUNSHADE

Exploded View

INFOID:000000012242620

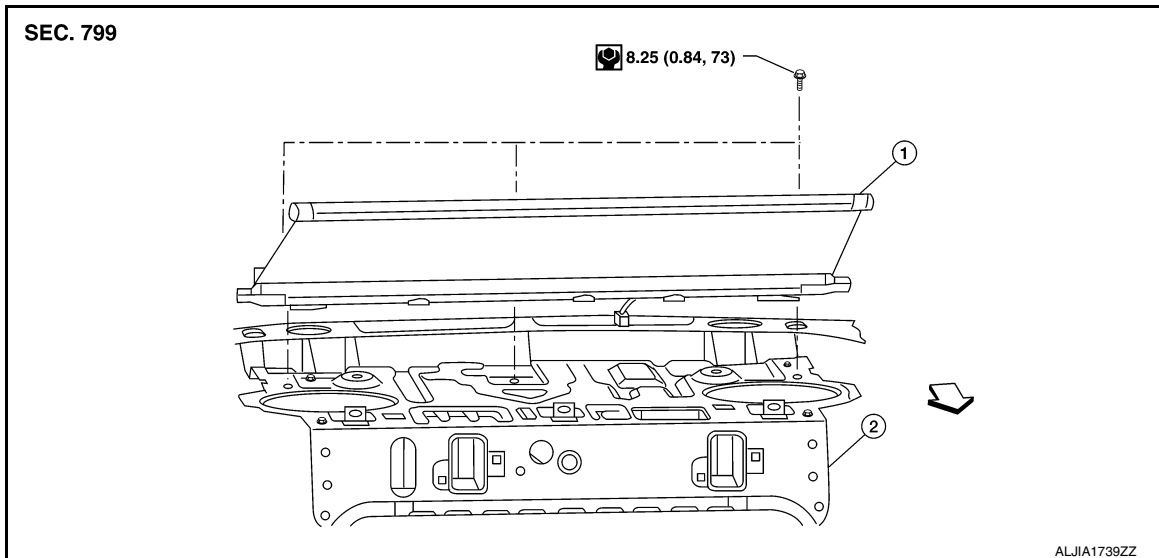

1. Rear sunshade

2. Rear parcel shelf body panel

← Front

## Removal and Installation

INFOID:000000011933627

### REMOVAL

1. Remove rear parcel shelf finisher. Refer to [INT-40, "Removal and Installation"](#).
2. Remove rear sunshade unit using the following steps.
  - a. Remove rear sunshade unit bolts.
  - b. Disconnect harness connector from rear sunshade unit, then remove rear sunshade unit.

### INSTALLATION

Installation is in the reverse order of removal.

# REAR SUNSHADE SWITCH

< REMOVAL AND INSTALLATION >

## REAR SUNSHADE SWITCH

Exploded View

INFOID:000000012226952

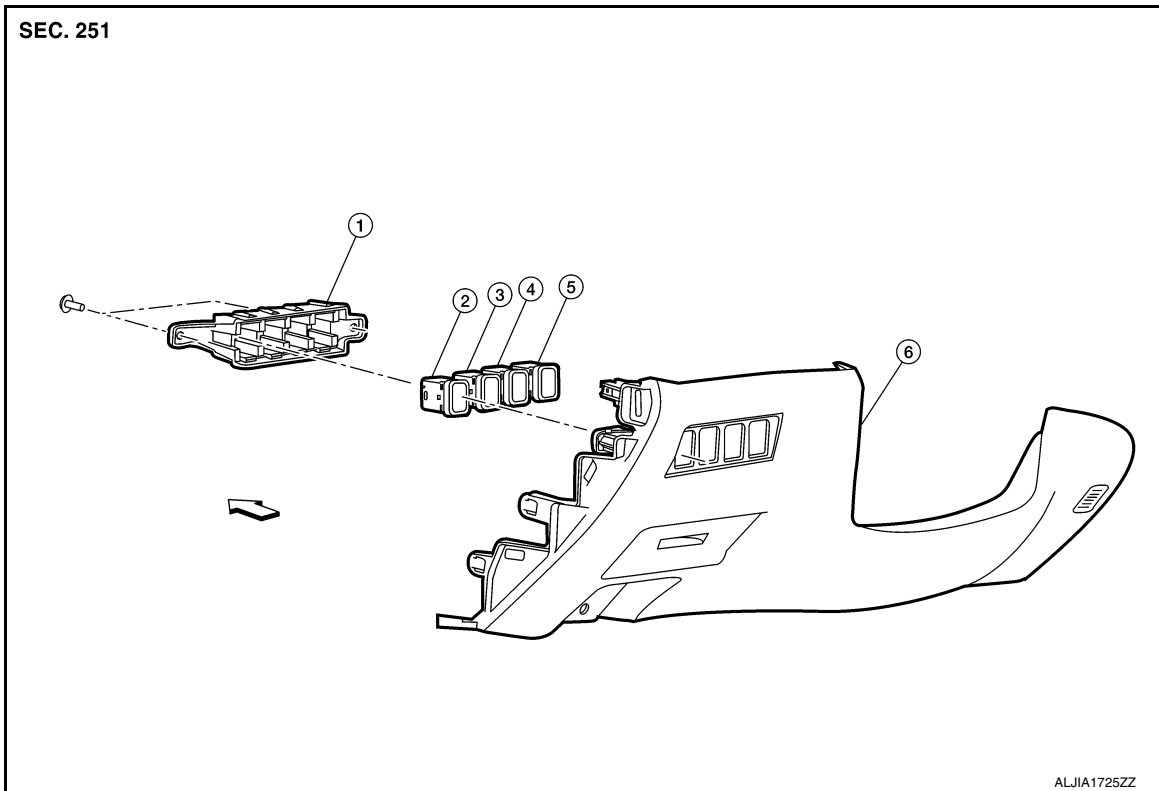

- |   |                         |                              |
|---|-------------------------|------------------------------|
| 1. Switch carrier                             | 2. Trunk lid switch     | 3. VDC OFF switch            |
| 4. Heated steering wheel switch (if equipped) | 5. Rear sunshade switch | 6. Instrument lower panel LH |

⇐ Front

## Removal and Installation

INFOID:000000012226875

### REMOVAL

1. Remove instrument lower panel LH. Refer to [IP-23. "Removal and Installation"](#).
2. Remove screws (A), then remove switch carrier (1) from instrument lower panel LH.

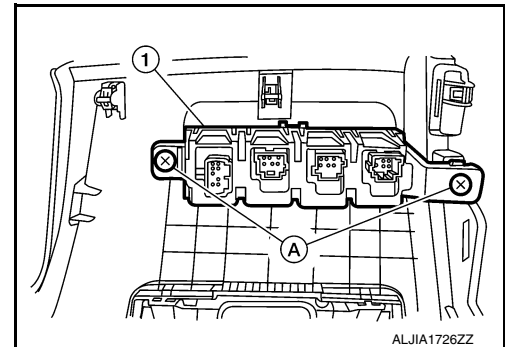

# REAR SUNSHADE SWITCH

## < REMOVAL AND INSTALLATION >

- Using a suitable tool, release pawls and remove rear sunshade switch.

 : Pawl

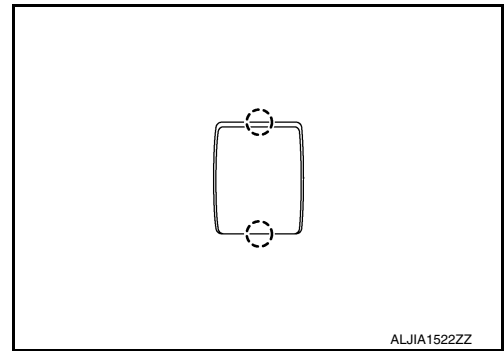

## INSTALLATION

Installation is in the reverse order of removal.

A  
B  
C  
D  
E  
F  
G  
H  
I  
K  
L  
M  
N  
O  
P

INT

# FLOOR TRIM

< REMOVAL AND INSTALLATION >

## FLOOR TRIM

Exploded View

INFOID:000000011933628

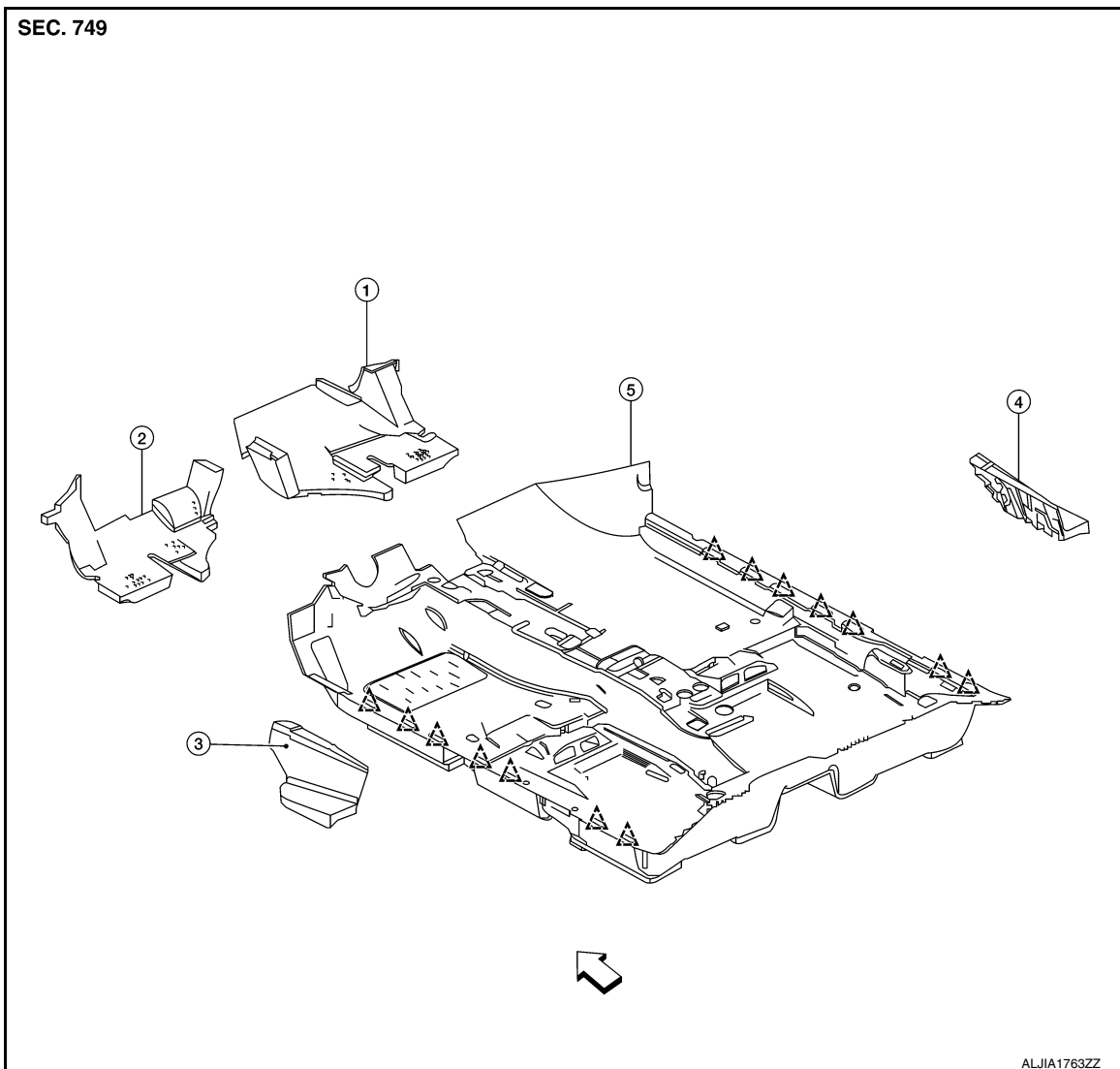

- |                       |                     |                       |
|-----------------------|---------------------|-----------------------|
| 1. Spacer (RH)        | 2. Spacer (LH)      | 3. Center spacer (LH) |
| 4. Center spacer (RH) | 5. Front floor trim | △ Harness clip        |

⇐ Front

## Removal and Installation

INFOID:000000011933629

### REMOVAL

1. Disconnect battery negative terminal and battery positive terminal. Refer to [PG-101, "Exploded View"](#).
2. Remove front seats (RH/LH). Refer to [SE-79, "Removal and Installation"](#).
3. Remove center console assembly. Refer to [IP-20, "Removal and Installation"](#).
4. Remove rear seat cushion. Refer to [SE-89, "Removal and Installation"](#).
5. Remove center pillar lower finishers (RH/LH). Refer to [INT-36, "CENTER PILLAR LOWER FINISHER : Removal and Installation"](#).
6. Remove dash side finishers. Refer to [INT-32, "DASH SIDE FINISHER : Removal and Installation"](#).

# FLOOR TRIM

## < REMOVAL AND INSTALLATION >

7. Remove instrument stay bracket nuts (A) and instrument stay bracket (1).

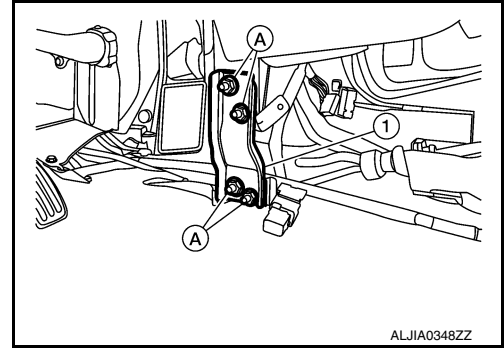

8. Remove front floor connecting duct (2) and front floor ducts [LH/ RH (1)] from heater and cooling unit. Refer to [VTL-8, "Exploded View"](#).

↔ : Front

9. Disconnect drain hose (4) from heater and cooling unit and set drain hose aside.
10. Remove bracket bolts (A), nut and bracket (3).

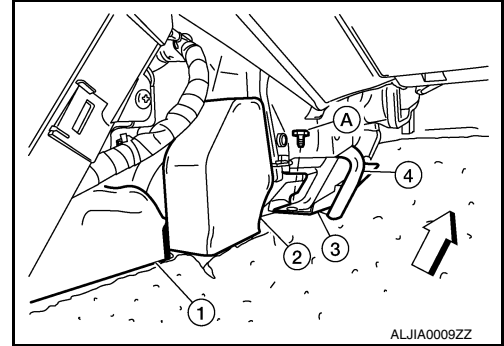

11. Release clips (A), then disconnect harness connectors (B) from center console and position center console harness (1) aside.

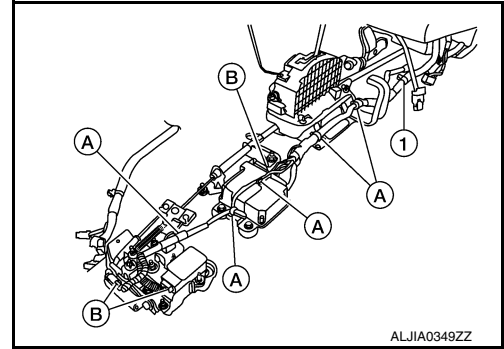

12. Remove parking brake cable nuts (A) and bolt and remove parking brake front cable (1). Position the parking brake front cable aside.

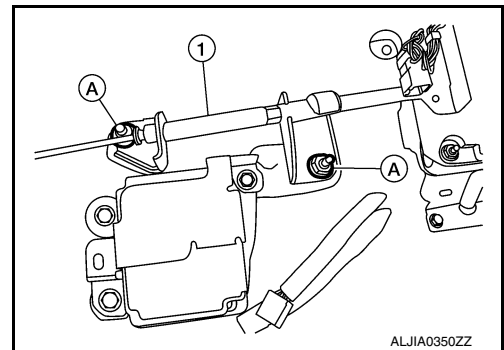

13. Remove around view monitor control unit. Refer to [AV-273, "Exploded View"](#).
14. Remove air bag diagnosis sensor unit. Refer to [SR-30, "Removal and Installation"](#).

A  
B  
C  
D  
E  
F  
G  
H  
I  
INT  
K  
L  
M  
N  
O  
P

## FLOOR TRIM

### < REMOVAL AND INSTALLATION >

15. Remove parking brake cable nuts (B). Position parking brake rear cables (2) aside.
16. Remove bracket nuts (C) and bolt (A), then remove extension bracket (3) and center console rear bracket (1).

⇐ : Front

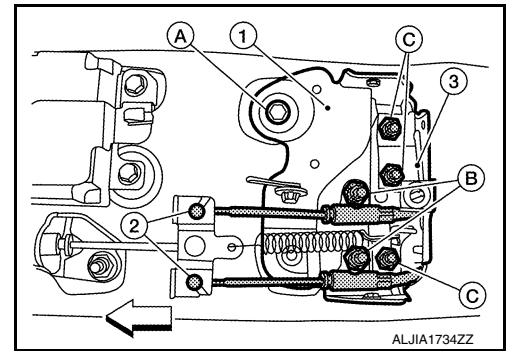

17. Remove shift selector. Refer to [TM-185, "Removal and Installation"](#).
18. Remove shift selector bracket bolts (A), and remove shift selector bracket (1).

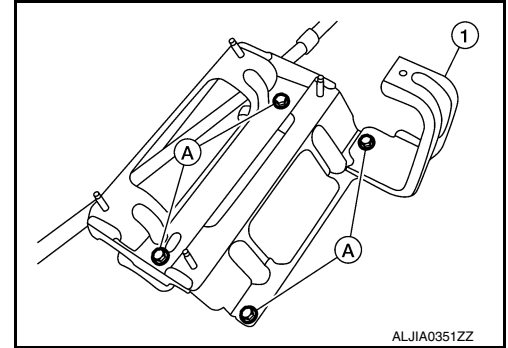

19. Release tab and remove floor mat hook.
20. Release pawls and open harness clamps, then remove harness and floor carpet cut-out areas from harness clamps.
21. Fold corners toward center, then remove floor carpet.

### INSTALLATION

Installation is in the reverse order of removal.

# HEADLINING

< REMOVAL AND INSTALLATION >

## HEADLINING

Exploded View

INFOID:000000011933630

WITHOUT SUNROOF

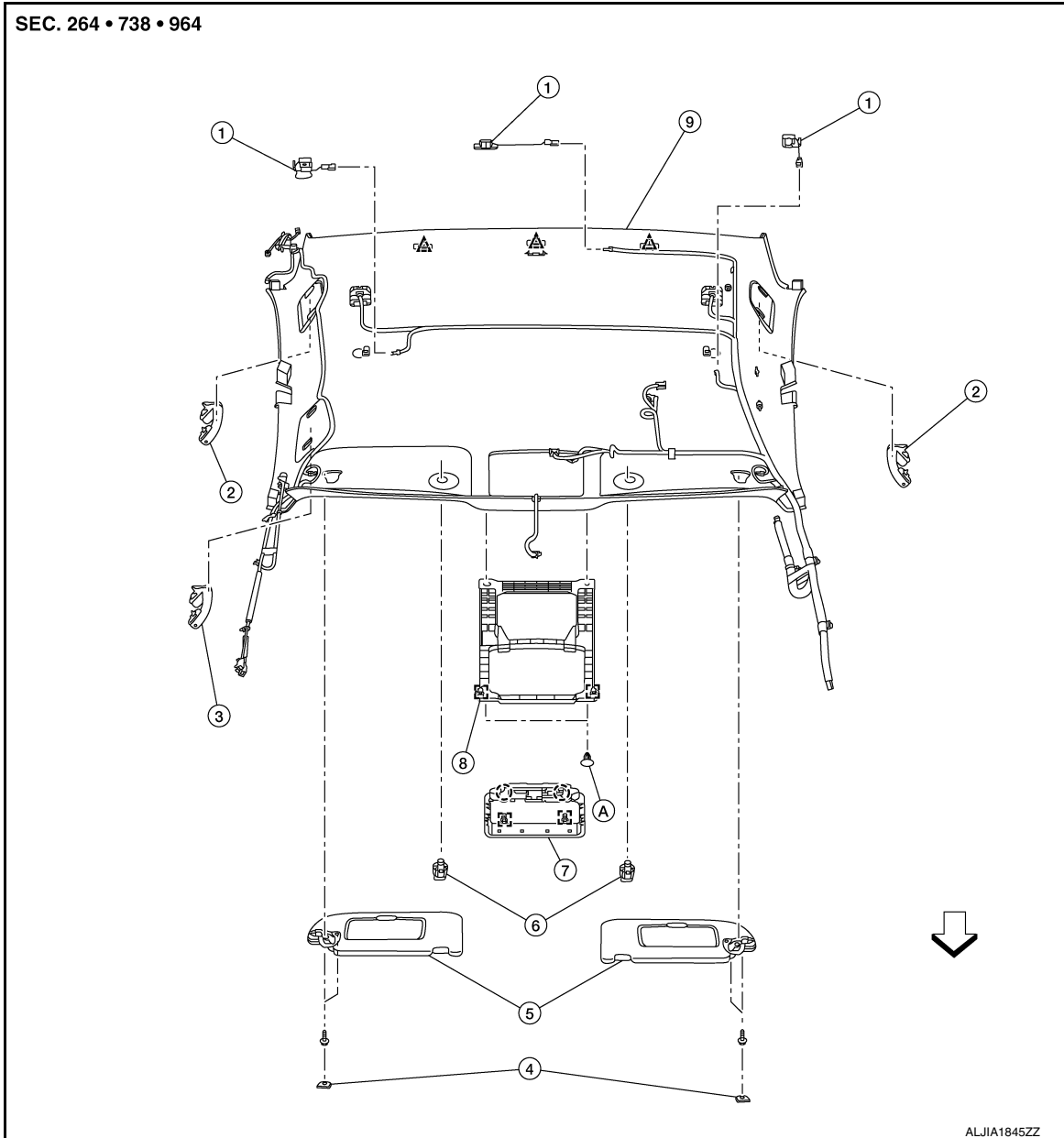

- |                                    |                                |                             |
|------------------------------------|--------------------------------|-----------------------------|
| 1. Active noise control microphone | 2. Rear assist grip (LH/RH)    | 3. Front assist grip        |
| 4. Sun visor cover (LH/RH)         | 5. Sun visors (RH/LH)          | 6. Sun visor holder (LH/RH) |
| 7. Front room/map lamp             | 8. Front room/map lamp bracket | 9. Headlining               |
| A. Clip                            | [dashed box] Metal clip        | [triangle with dot] Clip    |
| [circle with dot] Pawl             | [arrow] Front                  |                             |

A  
B  
C  
D  
E  
F  
G  
H  
I  
INT  
K  
L  
M  
N  
O  
P

# HEADLINING

< REMOVAL AND INSTALLATION >

WITH SUNROOF

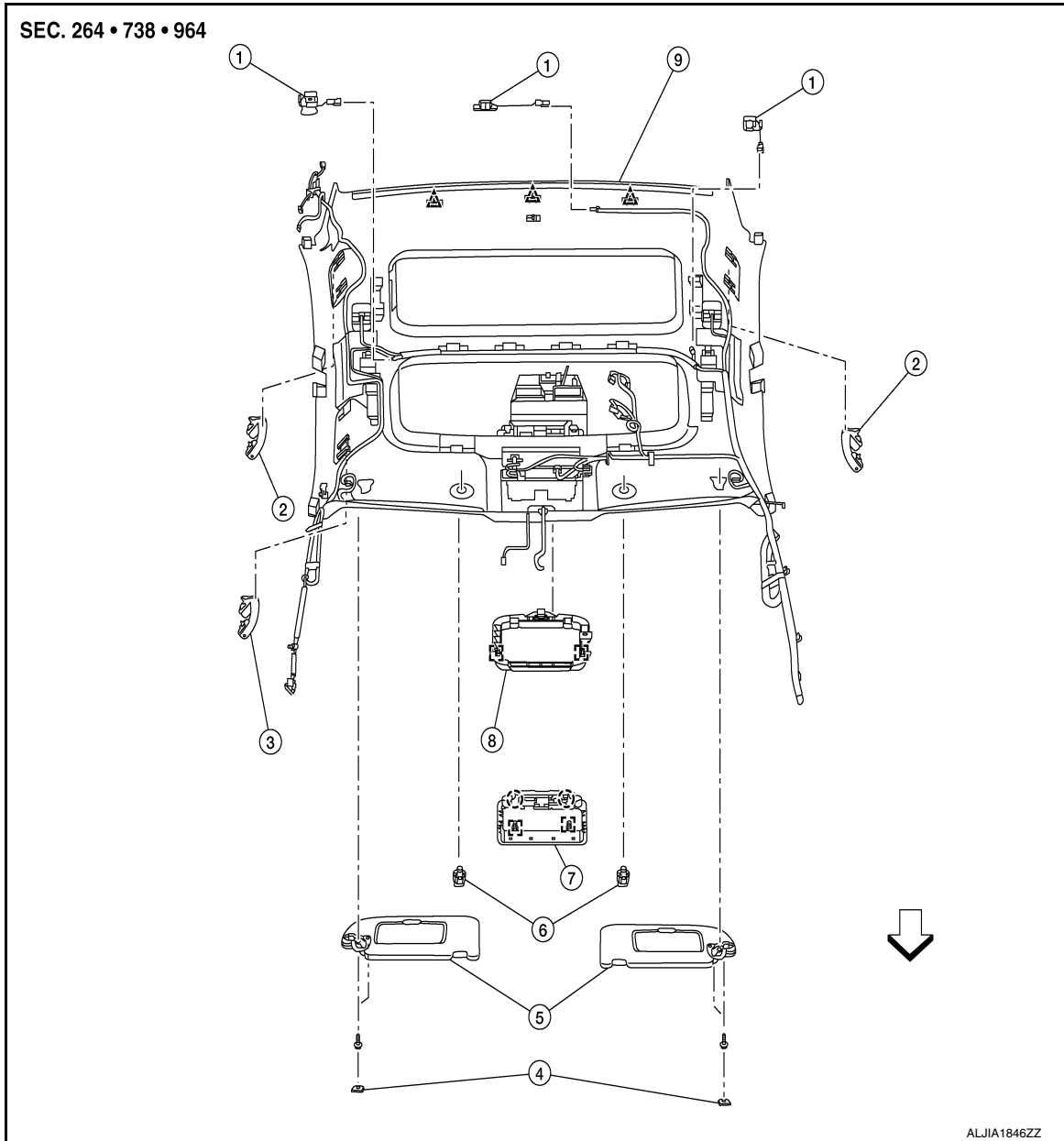

- |                                    |                                |                             |
|------------------------------------|--------------------------------|-----------------------------|
| 1. Active noise control microphone | 2. Rear assist grip (LH/RH)    | 3. Front assist grip        |
| 4. Sun visor cover (LH/RH)         | 5. Sun visors (RH/LH)          | 6. Sun visor holder (LH/RH) |
| 7. Front room/map lamp             | 8. Front room/map lamp bracket | 9. Headlining               |
| Metal clip                         | Clip                           | Pawl                        |
| Front                              |                                |                             |

## Removal and Installation

INFOID:000000011933631

### REMOVAL

1. Remove front seats (LH/RH). Refer to [SE-79, "Removal and Installation"](#).
2. Remove front pillar finishers (RH/LH). Refer to [INT-33, "FRONT PILLAR FINISHER : Removal and Installation"](#).
3. Disconnect headlining harness and antenna feeder connectors.
4. Remove center pillar upper finishers (RH/LH). Refer to [INT-36, "CENTER PILLAR UPPER FINISHER : Removal and Installation"](#).



# HEADLINING

## < REMOVAL AND INSTALLATION >

5. Remove rear pillar finishers (RH/LH). Refer to [INT-37. "REAR PILLAR FINISHER : Removal and Installation"](#).
6. Disconnect antenna amplifier and rear window defogger harness connectors.
7. Using suitable tool, release pawls and remove rain sensor finishers (1,3), then release pawls and remove inside mirror finisher (2).

 : Pawl

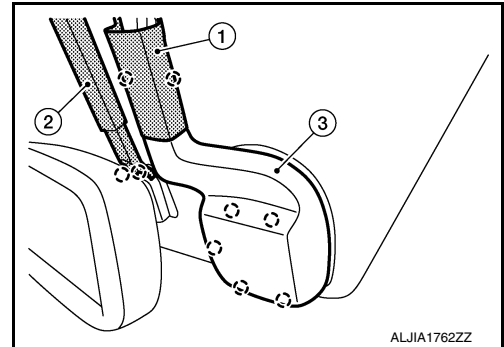

8. Disconnect harness connector from rain sensor and inside mirror.
9. Using suitable tool, release pawls and position assist grip caps open.

 : Pawl

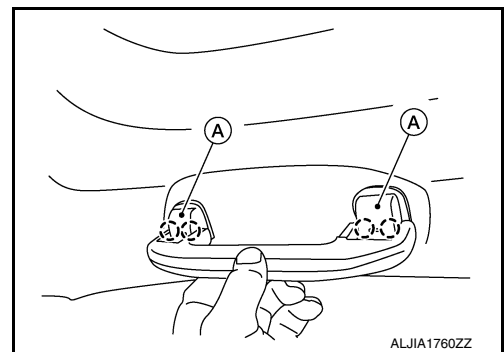

10. Remove screws (A) and then remove front and rear assist grips.

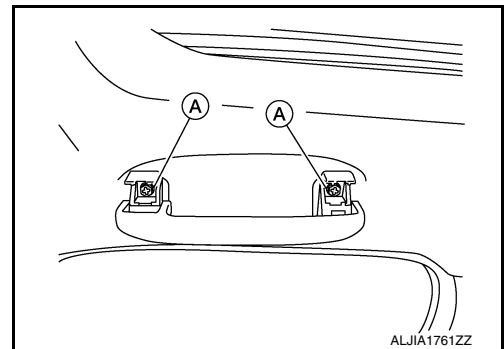

11. Remove sun visor cover [LH/RH (1)] by inserting suitable tool (A) as shown.

 : Pawl

**CAUTION:**  
Do not damage headlining or sun visor cover surface.

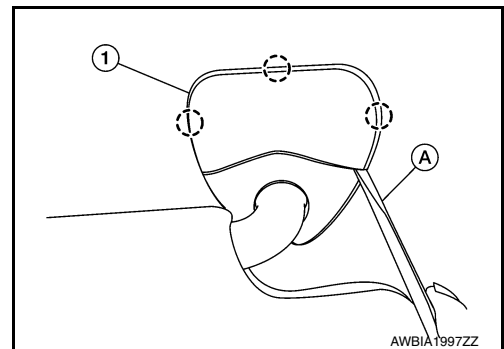

A  
B  
C  
D  
E  
F  
G  
H  
I  
INT  
K  
L  
M  
N  
O  
P

# HEADLINING

## < REMOVAL AND INSTALLATION >

12. Remove sun visor bolts (A) (LH/RH) then disconnect harness connectors and remove.

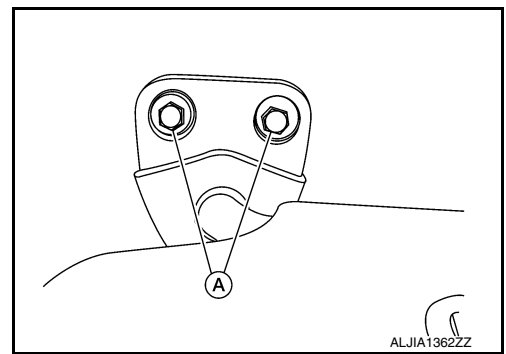

13. Insert suitable tool (A) at approximately a 30-degree angle into sun visor holder notch on front of sun visor holder (1). Press in to release locking tab (B). While holding in locking tab (B), turn sun visor holder (1) 90-degrees to release it from headliner.
- If sun visor holder (1) does not fully rotate, make sure that suitable tool (A) is pressing in on locking tab (B) and is not positioned under locking tab (B). Reinsert suitable tool (A) as necessary to release locking tab (B).

↔ : Front

### CAUTION:

Do not force sun visor holder when removing as locking tab may be damaged if suitable tool is not positioned correctly.

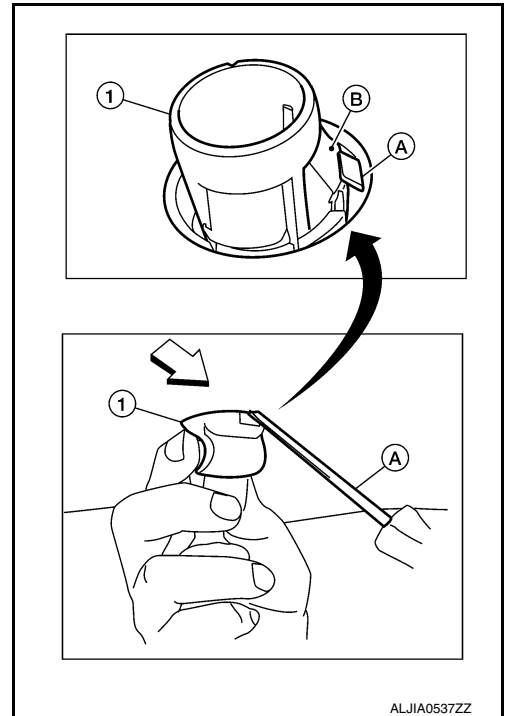

14. Remove front room/map lamp assembly. Refer to [INL-50. "Removal and Installation"](#).
15. If model is equipped with a sunroof, release dual lock fasteners around the sunroof opening.
16. Using suitable tool, release three hidden clips near rear edge of headlining.
17. Disconnect harness connectors from active noise control microphones (center/rear), then if necessary remove active noise control microphones (center/rear).
18. Lower headlining down and carefully rotate into position. Remove headlining through rear door opening.

### CAUTION:

- Two people are required for removal to prevent damage to headlining.
- Apply protective tape to the portion where contact may occur during work.
- Do not bend headlining when removing.

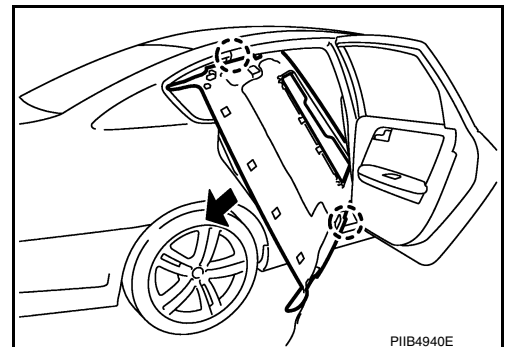

## INSTALLATION

Installation is in the reverse order of removal.

### CAUTION:

- When installing headlining, start by installing sun visor holders (LH/RH) and headlining clips at rear in order to keep the headlining in position.
- Do not to bend the headlining when installing.

# TRUNK ROOM TRIM & TRUNK LID FINISHER

< REMOVAL AND INSTALLATION >

## TRUNK ROOM TRIM & TRUNK LID FINISHER

Exploded View

INFOID:000000011933632

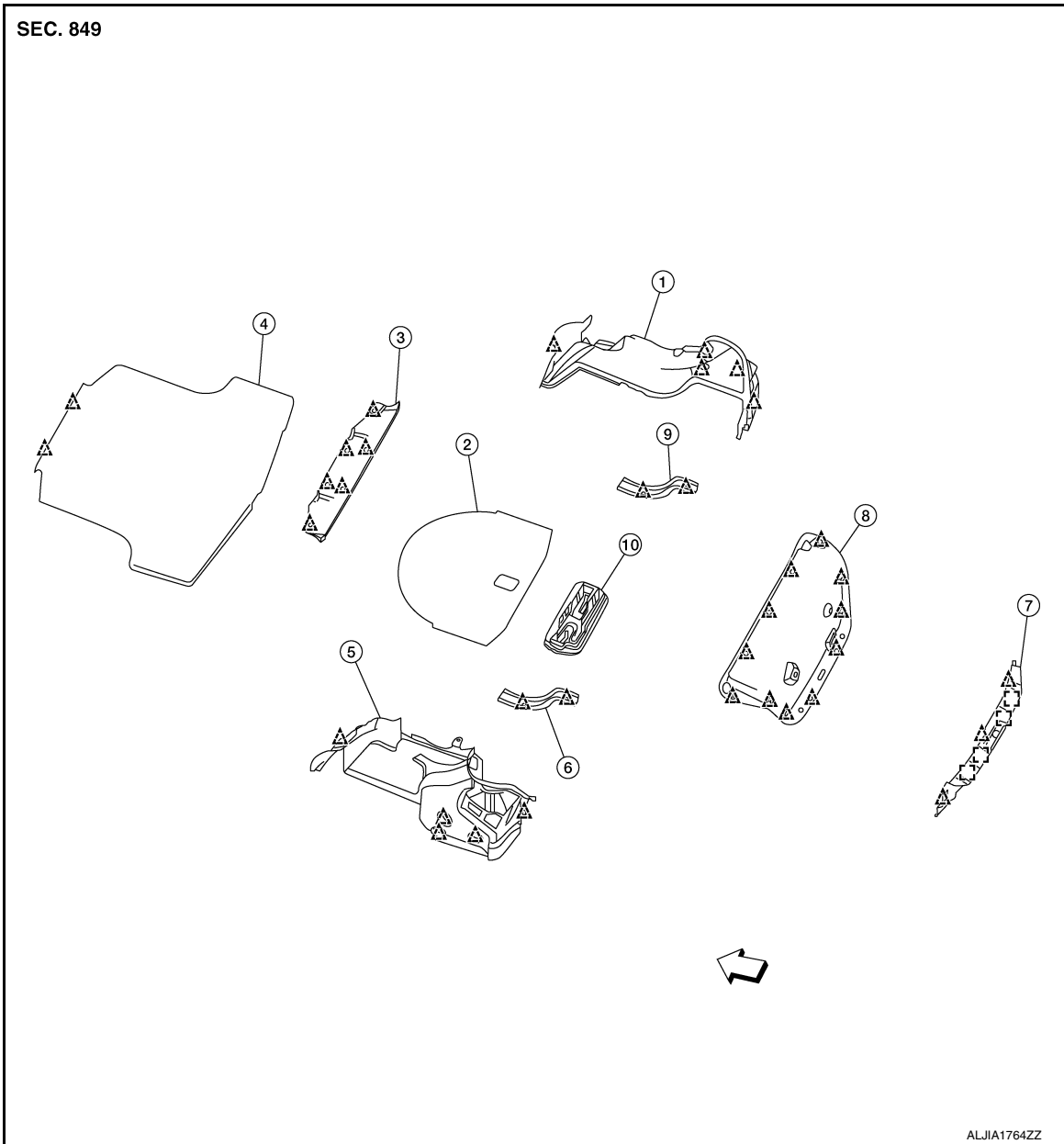

- |                             |                             |                              |
|-----------------------------|-----------------------------|------------------------------|
| 1. Trunk side finisher (RH) | 2. Spare tire cover         | 3. Trunk upper finisher      |
| 4. Trunk floor carpet       | 5. Trunk side finisher (LH) | 6. Trunk hinge finisher (LH) |
| 7. Trunk rear finisher      | 8. Trunk lid finisher       | 9. Trunk hinge finisher (RH) |
| 10. Box assembly            | Clip                        | Metal clip                   |

Front

### TRUNK LID FINISHER

### TRUNK LID FINISHER : Removal and Installation

INFOID:000000011933633

### REMOVAL

A  
B  
C  
D  
E  
F  
G  
H  
I  
INT  
K  
L  
M  
N  
O  
P

# TRUNK ROOM TRIM & TRUNK LID FINISHER

## < REMOVAL AND INSTALLATION >

1. Remove trunk lid rubber bumpers [LH/RH (A)].
2. Using a suitable tool, release clips.

 : Clip

3. Release emergency trunk release cable (1) from trunk lid finisher (2) and remove.

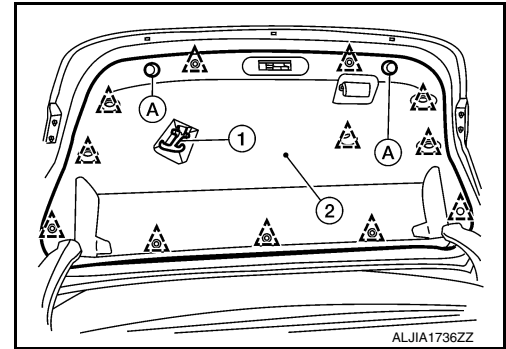

## INSTALLATION

Installation is in the reverse order of removal.

### CAUTION:

- Visually check clips for deformation and damage during installation. Replace with new ones if necessary.
- When installing trunk lid finisher, check that clips are securely placed in trunk lid holes.

## TRUNK FLOOR CARPET

### TRUNK FLOOR CARPET : Removal and Installation

INFOID:0000000012203301

## REMOVAL

1. Remove the rear seat cushion. Refer to [SE-89, "Removal and Installation"](#).
2. Remove the trunk floor carpet clips.

 : Clip

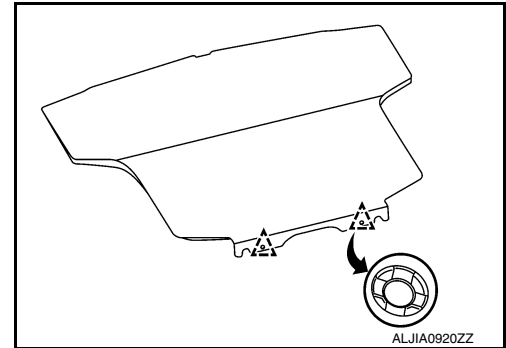

3. Remove the trunk floor carpet.

## INSTALLATION

Installation is in the reverse order of removal.

### CAUTION:

- Visually check clips for deformation and damage during installation. Replace with new ones if necessary.
- When installing trunk floor carpet, check that clips are securely placed in floor body holes.

## TRUNK SIDE FINISHER

### TRUNK SIDE FINISHER : Removal and Installation

INFOID:0000000012203302

## REMOVAL

1. Remove the rear seatback. Refer to [SE-89, "Removal and Installation"](#).
2. Remove the trunk rear finisher. Refer to [INT-54, "TRUNK REAR FINISHER : Removal and Installation"](#).

# TRUNK ROOM TRIM & TRUNK LID FINISHER

## < REMOVAL AND INSTALLATION >

- Using a suitable tool, release clips.

 : Clip

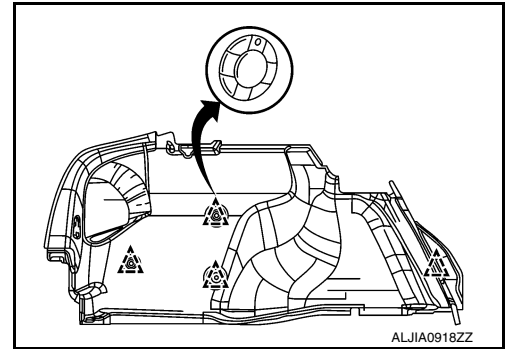

- Remove the trunk side finisher.

## INSTALLATION

Installation is in the reverse order of removal.

### CAUTION:

- Visually check clips for deformation and damage during installation. Replace with new ones if necessary.
- When installing trunk side finisher, check that clips are securely placed in trunk panel holes.

## TRUNK UPPER FINISHER

### TRUNK UPPER FINISHER : Removal and Installation

INFOID:0000000012241278

## REMOVAL

- Using a suitable tool, release hook fasteners (LH/RH), then release clips [LH/RH (A)].

### NOTE:

LH shown, RH similar.

 : Hook fastener

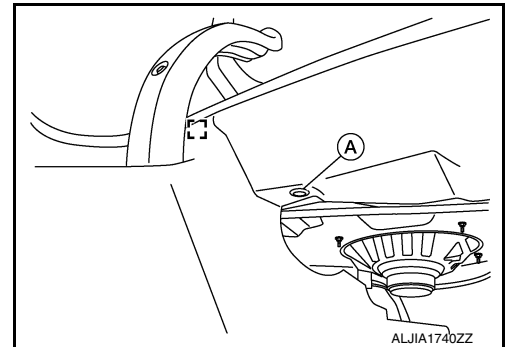

- Using a suitable tool, release clips (A), then route rear seatback release straps (2) through trunk upper finisher (1) and remove.

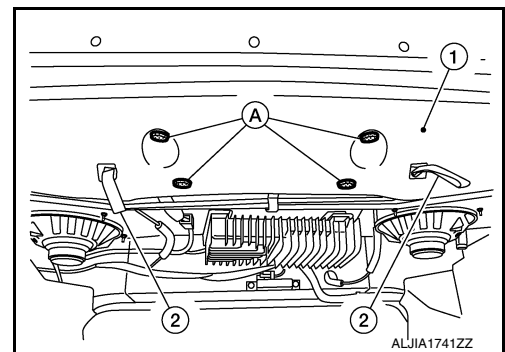

## INSTALLATION

Installation is in the reverse order of removal.

### CAUTION:

- Visually check clips for deformation and damage during installation. Replace with new ones if necessary.
- When installing trunk upper finisher, check that clips are securely placed in trunk body panel holes.

## TRUNK REAR FINISHER

A  
B  
C  
D  
E  
F  
G  
H  
I  
INT  
K  
L  
M  
N  
O  
P

# TRUNK ROOM TRIM & TRUNK LID FINISHER

< REMOVAL AND INSTALLATION >

## TRUNK REAR FINISHER : Removal and Installation

INFOID:000000012203303

### REMOVAL

1. Using a suitable tool, release clips.

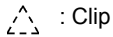

: Clip

2. Using a suitable tool, release metal clips then remove trunk rear finisher.

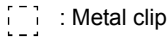

: Metal clip

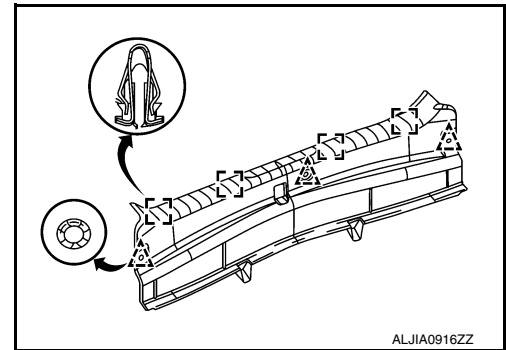

### INSTALLATION

Installation is in the reverse order of removal.

## TRUNK HINGE FINISHER

### TRUNK HINGE FINISHER : Removal and Installation

INFOID:000000012461123

### REMOVAL

#### NOTE:

LH shown, RH similar.

1. Remove trunk lid finisher. Refer to [INT-51, "TRUNK LID FINISHER : Removal and Installation"](#).
2. Using a suitable tool release hook and loop fasteners (LH/RH), then release clips [LH/RH (A)].

#### NOTE:

LH shown, RH similar.

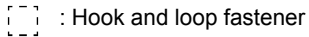

: Hook and loop fastener

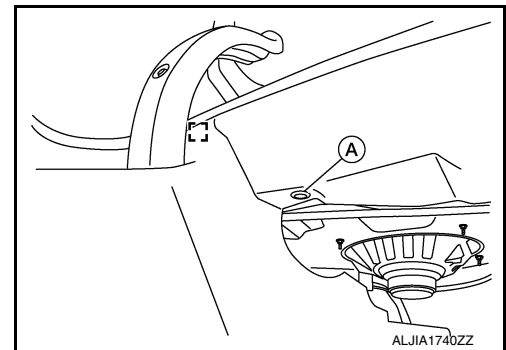

3. Release clips (A) then remove trunk hinge finisher (1).

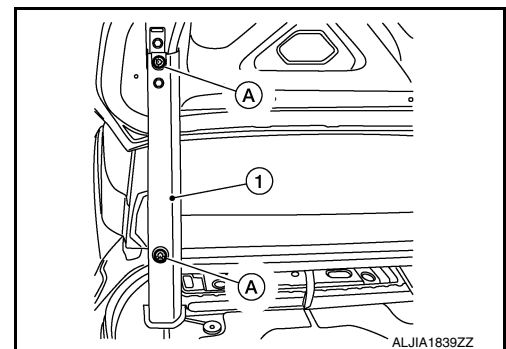

### INSTALLATION

Installation is in the reverse order of removal.

#### CAUTION:

- Visually check clips for deformation and damage during installation. Replace with new ones if necessary.
- When installing trunk hinge finisher, check that clips are securely placed in trunk hinge holes.